



.....
Cheetah X15 FC Disc Drive
.....

ST318451FC
.....

.....
Product Manual, Volume 1
.....

.....
Cheetah X15 FC Disc Drive
.....

ST318451FC
.....

.....
Product Manual, Volume 1
.....

© 2000, 2001 Seagate Technology LLC All rights reserved

August 2001

Publication number: 83329486, Rev. C

Seagate, Seagate Technology, and the Seagate logo are registered trademarks of Seagate Technology LLC. Cheetah, SeaFAX, SeaFONE, SeaBOARD, and SeaTDD are either registered trademarks or trademarks of Seagate Technology LLC. Other product names are registered trademarks or trademarks of their owners.

Seagate reserves the right to change, without notice, product offerings or specifications. No part of this publication may be reproduced in any form without written permission of Seagate Technology LLC.

Printed in the United States of America

Revision status summary sheet

Revision	Date	Writer/Engineer	Sheets Affected
A (Class A Release)	06/01/2000	L. Newman/G. Velaski	1/1, v-viii, 1-68.
B	07/12/2000	K. Schweiss/G. Velaski	front cover, pages 6, 7, 9, 11, 17 (add Thermal Monitor section), 25, 32, 46, and back cover
C	08/7/2001	L. Newman/J. Nowitzke	Pages 4, 6, 38, 41, 52, 55, and 59-61.

Contents

1.0	Scope	1
2.0	Applicable standards and reference documentation	3
2.1	Standards	3
2.1.1	Electromagnetic compatibility	3
2.1.2	Electromagnetic compliance	3
2.2	Reference documents	4
3.0	General description	5
3.1	Standard features	6
3.2	Media description	6
3.3	Performance	6
3.4	Reliability	7
3.5	Unformatted and formatted capacities	7
3.6	Programmable drive capacity	7
3.7	Factory-installed accessories	7
3.8	Factory-installed options	7
3.9	User-installed accessories	7
4.0	Performance characteristics	9
4.1	Internal drive characteristics	9
4.2	Seek performance characteristics	9
4.2.1	Access time	9
4.2.2	Format command execution time for ≥ 512 -byte sectors	9
4.2.3	General performance characteristics	10
4.3	Start/stop time	10
4.4	Prefetch/multi-segmented cache control	10
4.5	Cache operation	11
4.5.1	Caching write data	11
4.5.2	Prefetch operation	12
5.0	Reliability specifications	13
5.1	Error rates	13
5.1.1	Environmental interference	13
5.1.2	Write errors	13
5.1.3	Seek errors	13
5.2	Reliability and service	14
5.2.1	Mean time between failure (MTBF)	14
5.2.2	Field failure rate vs time	14
5.2.3	Preventive maintenance	15
5.2.4	Service life	15
5.2.5	Service philosophy	15
5.2.6	Service tools	15
5.2.7	Hot plugging the drive	15
5.2.8	S.M.A.R.T.	15
5.2.9	Thermal Monitor	17
5.2.10	Drive Self Test (DST)	17
5.2.11	Product warranty	19
6.0	Physical/electrical specifications	21
6.1	AC power requirements	21
6.2	DC power requirements	21
6.2.1	Conducted noise immunity	22
6.2.2	Power sequencing	22
6.2.3	Current profiles	22
6.3	Power dissipation	24
6.4	Environmental limits	24
6.4.1	Temperature	24

6.4.2	Relative humidity	26
6.4.3	Effective altitude (sea level)	26
6.4.4	Shock and vibration	26
6.4.5	Air cleanliness	28
6.4.6	Acoustics	28
6.4.7	Electromagnetic susceptibility	28
6.5	Mechanical specifications	29
7.0	Defect and error management	31
7.1	Drive internal defects/errors	31
7.2	Drive error recovery procedures	31
7.3	FC-AL system errors	32
8.0	Installation	33
8.1	Drive ID/option selection	33
8.2	LED connections	33
8.2.1	J6 connector requirements	34
8.3	Drive orientation	34
8.4	Cooling	34
8.4.1	Air flow	35
8.5	Drive mounting	35
8.6	Grounding	36
9.0	Interface requirements	37
9.1	FC-AL features	37
9.1.1	Fibre Channel link service frames	37
9.1.2	Fibre Channel task management functions	37
9.1.3	Fibre Channel task management responses	37
9.1.4	Fibre Channel port login	38
9.1.5	Fibre Channel port login accept	39
9.1.6	Fibre Channel Process Login	39
9.1.7	Fibre Channel Process Login Accept	39
9.1.8	Fibre Channel fabric login	40
9.1.9	Fibre Channel fabric accept login	41
9.1.10	Fibre Channel Arbitrated Loop options	42
9.2	Dual port support	42
9.3	SCSI commands supported	43
9.3.1	Inquiry data	46
9.3.2	Mode Sense data	46
9.4	Miscellaneous operating features and conditions	49
9.5	FC-AL physical interface	50
9.5.1	Physical characteristics	50
9.5.2	Connector requirements	51
9.5.3	Electrical description	52
9.5.4	Pin descriptions	52
9.5.5	FC-AL transmitters and receivers	53
9.5.6	Power	53
9.5.7	Fault LED Out	53
9.5.8	Active LED Out	53
9.5.9	Enable port bypass signals	54
9.5.10	Motor start controls	54
9.5.11	SEL_6 through SEL_0 ID lines	54
9.5.12	Device control codes	55
9.6	Signal characteristics	57
9.6.1	TTL input characteristics	57
9.6.2	LED driver signals	57
9.6.3	Differential PECL output	57
9.6.4	Differential PECL input	58
10.0	Seagate Technology support services	59

List of Figures

Figure 1.	Cheetah X15 FC family disc drive	1
Figure 2.	Cheetah X15 FC disc drive	5
Figure 3.	Typical ST318451FC drive +12V current profile	22
Figure 4.	Typical ST318451FC drive +5V current profile	23
Figure 5.	DC current and power vs. input/output operations per second	24
Figure 6.	Locations of PCBA components listed in Table 3	25
Figure 7.	Recommended mounting	27
Figure 8.	Mounting configuration dimensions	29
Figure 9.	Physical interface	33
Figure 10.	LED indicator connector	34
Figure 11.	Air flow	35
Figure 12.	Physical interface	50
Figure 13.	Port bypass circuit physical interconnect	50
Figure 14.	FC-AL SCA device connector dimensions	51
Figure 15.	J6 connector dimensions	51
Figure 16.	FC-AL transmitters and receivers	53
Figure 17.	Transmit eye diagram	58
Figure 18.	Receive eye diagram	58

1.0 Scope

This manual describes Seagate Technology[®] LLC, Cheetah X15 FC (Fibre Channel) disc drives.

Cheetah X15 FC drives support the Fibre Channel Arbitrated Loop and SCSI Fibre Channel Protocol specifications to the extent described in this manual. The *Fibre Channel Interface Manual* (part number 77767496) describes the general Fibre Channel Arbitrated Loop characteristics of this and other Seagate Fibre Channel drives.

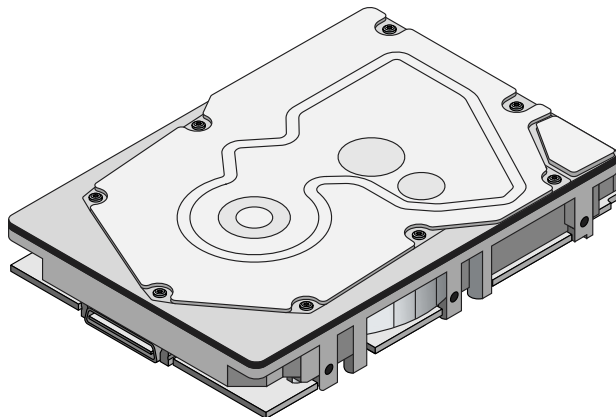

Figure 1. Cheetah X15 FC family disc drive

2.0 Applicable standards and reference documentation

The drive has been developed as a system peripheral to the highest standards of design and construction. The drive depends upon its host equipment to provide adequate power and environment in order to achieve optimum performance and compliance with applicable industry and governmental regulations. Special attention must be given in the areas of safety, power distribution, shielding, audible noise control, and temperature regulation. In particular, the drive must be securely mounted in order to guarantee the specified performance characteristics. Mounting by bottom holes must meet the requirements of Section 8.5.

2.1 Standards

The Cheetah X15 FC family complies with Seagate standards as noted in the appropriate sections of this manual and the Seagate *Fibre Channel Interface Manual*, part number 77767496.

The Cheetah X15 FC disc drive is a UL recognized component per UL1950, CSA certified to CAN/CSA C22.2 No. 950-95, and VDE certified to VDE 0805 and EN60950.

2.1.1 Electromagnetic compatibility

The drive, as delivered, is designed for system integration and installation into a suitable enclosure prior to use. As such the drive is supplied as a subassembly and is not subject to Subpart B of Part 15 of the FCC Rules and Regulations nor the Radio Interference Regulations of the Canadian Department of Communications.

The design characteristics of the drive serve to minimize radiation when installed in an enclosure that provides reasonable shielding. As such, the drive is capable of meeting the Class B limits of the FCC Rules and Regulations of the Canadian Department of Communications when properly packaged. However, it is the user's responsibility to assure that the drive meets the appropriate EMI requirements in their system. Shielded I/O cables may be required if the enclosure does not provide adequate shielding. If the I/O cables are external to the enclosure, shielded cables should be used, with the shields grounded to the enclosure and to the host controller.

2.1.1.1 Electromagnetic susceptibility

As a component assembly, the drive is not required to meet any susceptibility performance requirements. It is the responsibility of those integrating the drive within their systems to perform those tests required and design their system to ensure that equipment operating in the same system as the drive or external to the system does not adversely affect the performance of the drive. See Section 5.1.1 and Table 2, DC power requirements.

2.1.2 Electromagnetic compliance

Seagate uses an independent laboratory to confirm compliance with the directives/standards for CE Marking and C-Tick Marking. The drive was tested in a representative system for typical applications. The selected system represents the most popular characteristics for test platforms. The system configurations include:

- Typical current use microprocessor
- 3.5-inch floppy disc drive
- Keyboard
- Monitor/display
- Printer
- External modem
- Mouse

Although the test system with this Seagate model complies with the directives/standards, we cannot guarantee that all systems will comply. The computer manufacturer or system integrator shall confirm EMC compliance and provide the appropriate marking for their product.

Electromagnetic compliance for the European Union

If this model has the CE Marking it complies with the European Union requirements of the Electromagnetic Compatibility Directive 89/336/EEC of 03 May 1989 as amended by Directive 92/31/EEC of 28 April 1992 and Directive 93/68/EEC of 22 July 1993.

Australian C-Tick

If this model has the C-Tick Marking it complies with the Australia/New Zealand Standard AS/NZS3548 1995 and meets the Electromagnetic Compatibility (EMC) Framework requirements of Australia's Spectrum Management Agency (SMA).

Korean MIC

If this model has the Korean Ministry of Information and Communication (MIC) logo, it complies with paragraph 1 of Article 11 of the Electromagnetic Compatibility (EMC) Control Regulation and meets the Electromagnetic Compatibility Framework requirements of the Radio Research Laboratory (RRL) Ministry of Information and Communication Republic of Korea.

Taiwanese BSMI

If this model has two Chinese words meaning "EMC certification" followed by an eight digit identification number, as a Marking, it complies with Chinese National Standard (CNS) 13438 and meets the Electromagnetic Compatibility (EMC) Framework requirements of the Taiwanese Bureau of Standards, Metrology, and Inspection (BSMI).

2.2 Reference documents

Cheetah X15 FC Installation Guide

Seagate part number: 83329487

Fibre Channel Interface Manual

Seagate part number: 77767496

ANSI Fibre Channel Documents

X3.230-1994	FC Physical and Signaling Interface (FC-PH)
X3.297.1997	FC-PH-2 Fibre Channel Physical and Signaling Interface-2
X3.303.1998	FC-PH-3 Fibre Channel Physical and Signaling Interface-3
X3.272-1996	FC Arbitrated Loop (FC-AL)
X3.269-1996	Fibre Channel Protocol for SCSI (FCP)
NCITS TR-19	Private Loop SCSI Direct Attach (PLDA)
NCITS TR-20	Fabric Loop Attachment (FC-FLA)
SFF-8045	Specification for 40-pin SCA-2 Connector with Parallel Selection.
SFF-8067	Specification for 40-pin SCA-2 Connector with Bidirectional Enclosure Services Interface

ANSI Small Computer System Interface (SCSI) Documents

X3.131-1994	(SCSI-2)
X3.270-1996	(SCSI-3) Architecture Model
NCITS 305-199X	(SCSI-3) Enclosure Services
30553-001	Specification for Acoustic Test Requirement and Procedures

In case of conflict between this document and any referenced document, this document takes precedence.

3.0 General description

Cheetah X15™ FC drives combine giant magnetoresistive (GMR) heads, partial response/maximum likelihood (PRML) read channel electronics, embedded servo technology, and a Fibre Channel interface to provide high performance, high capacity data storage for a variety of systems including engineering workstations, network servers, mainframes, and supercomputers. Cheetah X15 FC drives also support 2-Gbit Fibre Channel which can transfer data at up to 200 Mbytes per second and 400 Mbytes per second in dual-loop configurations.

Cheetah X15 FC drives are random access storage devices designed to support the Fibre Channel Arbitrated Loop (FC-AL) and SCSI Fibre Channel Protocol as described in the ANSI specifications, this document, and the *Fibre Channel Interface Manual* (part number 77767496) which describes the general interface characteristics of this drive. Cheetah X15 FC drives are classified as intelligent peripherals and provide level 2 conformance (highest level) with the ANSI SCSI-1 standard.

The head and disc assembly (HDA) is sealed at the factory. Air recirculates within the HDA through a non-replaceable filter to maintain a contamination-free HDA environment.

See Figure 2 for an exploded view of the drive. Never disassemble the HDA. This exploded view is for information only. Do not attempt to service items in the sealed enclosure (heads, media, actuator, etc.) as this requires special facilities. The drive contains no parts replaceable by the user and opening the HDA for any reason voids your warranty.

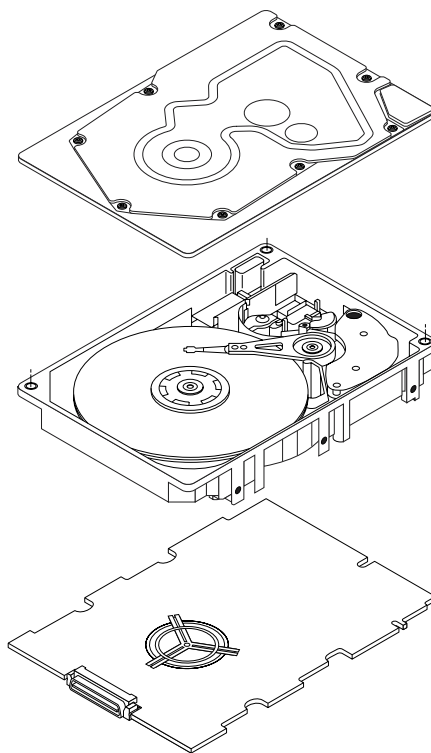

Figure 2. Cheetah X15 FC disc drive

Cheetah X15 FC drives use a dedicated landing zone at the innermost radius of the media to eliminate the possibility of destroying or degrading data by landing in the data zone. The heads automatically go to the landing zone when power is removed from the drive.

An automatic shipping lock prevents potential damage to the heads and discs that results from movement during shipping and handling. The shipping lock disengages and the head load process begins when power is applied to the drive.

Cheetah X15 FC drives decode track 0 location data from the servo data embedded on each surface to eliminate mechanical transducer adjustments and related reliability concerns.

The drives also use a high-performance actuator assembly with a low-inertia, balanced, patented, straight arm design that provides excellent performance with minimal power dissipation.

3.1 Standard features

Cheetah X15 FC drives have the following standard features:

- 2-Gbit Fibre Channel interface. For 2 gigabit operation, the block size must be divisible by 8.
- Integrated dual port FC-AL controller
- Concurrent dual port transfers
- Support for FC arbitrated loop, private and public attachment
- Differential copper FC drivers and receivers
- Downloadable firmware using the FC-AL interface
- Supports SCSI enclosure services via interface connector
- 128-deep task set (queue)
- Supports up to 32 initiators
- Drive selection ID and configuration options are set on the FC-AL backpanel or through interface commands. Jumpers are not used on the drive.
- Supports SCSI Enclosure Services through the interface connector
- Fibre Channel worldwide name uniquely identifies the drive and each port
- User-selectable logical block size (512 to 704 bytes per logical block). For 2 gigabit operation, the block size must be divisible by 8.
- Selectable frame sizes from 256 to 2,112 bytes
- Industry standard 3.5-inch low profile form factor dimensions
- Programmable logical block reallocation scheme
- Flawed logical block reallocation at format time
- Programmable auto write and read reallocation
- Reed-Solomon error correction code
- Sealed head and disc assembly (HDA)
- No preventive maintenance or adjustments required
- Dedicated head landing zone
- Automatic shipping lock
- Embedded Grey Code track address to eliminate seek errors
- Self-diagnostics performed at power on
- 1:1 interleave
- Zone bit recording (ZBR)
- Vertical, horizontal, or top down mounting
- Dynamic spindle brake
- 4,096 Kbyte data buffer
See Section 4.5
- Embedded servo design
- Reallocation of defects on command (Post Format)
- Fibre Channel interface transports SCSI protocol

3.2 Media description

The media used on the drive has an aluminum substrate coated with a thin film magnetic material, overcoated with a proprietary protective layer for improved durability and environmental protection.

3.3 Performance

- Programmable multi-segmentable cache buffer
- 200 Mbytes/sec maximum instantaneous data transfers per port.
- 15k RPM spindle; average latency = 2.0 msec
- Command queuing of up to 128 commands
- Background processing of queue
- Supports start and stop commands
- Adaptive seek velocity; improved seek performance

3.4 Reliability

- 1,200,000 hour MTBF
- LSI circuitry
- Balanced low mass rotary voice coil actuator
- Self-Monitoring Analysis and Reporting Technology (S.M.A.R.T.)
- Dithering

3.5 Unformatted and formatted capacities

Formatted capacity depends on the spare reallocation sectors scheme selected, the number of data tracks per sparing zone, and the number of alternate sectors (LBAs) per sparing zone. The following table shows the standard OEM model capacity:

	Formatted	Unformatted
ST318451FC	0222EE56h (18.4) Gbytes	23.86 Gbytes

Standard OEM models are formatted to 512 bytes per block. You can order other capacities by requesting a different sparing scheme and logical block size.

Note. For 2 gigabit operation sector sizes must be divisible by 8.

The sector size is selectable at format time. Users having the necessary equipment may modify the data block size before issuing a format command and obtain different formatted capacities than those listed. ST318451FC drives use a zone sparing scheme. The drive is divided into frequency zones with a variable number of spares in each zone.

3.6 Programmable drive capacity

Using the Mode Select command, the drive can change its capacity to something less than maximum. See the Mode Select (6) parameter list table in the *Fibre Channel Interface Manual*, part number 7767496. A value of zero in the Number of Blocks field indicates that the drive will not change the capacity it is currently formatted to have. A number other than zero and less than the maximum number of LBAs in the Number of Blocks field changes the total drive capacity to the value in the Number of Blocks field. A value greater than the maximum number of LBAs is rounded down to the maximum capacity.

3.7 Factory-installed accessories

OEM standard drives are shipped with the *Cheetah X15 FC Installation Guide* (part number 83329487).

3.8 Factory-installed options

You may order the following items which are incorporated at the manufacturing facility during production or packaged before shipping. Some of the options available are (not an exhaustive list of possible options):

- Other capacities can be ordered depending on sparing scheme and sector size requested.
- Single-unit shipping pack. The drive is normally shipped in bulk packaging to provide maximum protection against transit damage. Units shipped individually require additional protection as provided by the single unit shipping pack. Users planning single unit distribution should specify this option.
- The *Cheetah X15 FC Installation Guide*, part number 83329487, is usually included with each standard OEM drive shipped, but extra copies may be ordered.
- The *Safety and Regulatory Agency Specifications*, part number 75789512, is usually included with each standard OEM drive shipped, but extra copies may be ordered.

3.9 User-installed accessories

The following accessories are available. All kits may be installed in the field.

- Evaluation kit, part number 73473641.
This kit provides an adapter card ("T-card") to allow cable connections for two FC ports and DC power. Two twin axial cables, 6 feet in length, are included for the input and output connections to the FC interface.
- Single-unit shipping pack.

4.0 Performance characteristics

This section provides detailed information concerning performance-related characteristics and features of Cheetah X15 FC drives.

4.1 Internal drive characteristics

		ST318451FC		
Drive capacity	18.35	Gbytes (formatted, rounded off value)		
Read/write data heads	10			
Bytes per track	176,843	Bytes (average, rounded off values)		
Bytes per surface	1,835	Mbytes (unformatted, rounded off value)		
Tracks per surface (total)	10,377	Tracks (user accessible)		
Tracks per inch	21,400	TPI		
Peak bits per inch	343	KBPI		
Internal data rate	385-512	Mbits/sec (variable with zone)		
Disc rotation speed	15k.....	rpm		
Avg rotational latency	2.0	msec		

4.2 Seek performance characteristics

See Section 9.5, "FC-AL physical interface" on page 50 and the *Fibre Channel Interface Manual* (part number 77767496) for additional timing details.

4.2.1 Access time

		Including controller overhead (without disconnect)^{1, 2} (msec)		Not including controller overhead (without disconnect)^{1, 2} (msec)	
		Read	Write	Read	Write
Average	Typical ^{3,4}	4.1	4.7	3.9	4.5
Single track	Typical ^{3,4}	0.8	1.0	0.5	0.7
Full stroke	Typical ^{3,4}	7.7	8.2	7.5	8.0

1. Execution time measured from receipt of the FCP Command to the FCP Response.
2. Assumes no errors and no sector has been relocated.
3. Typical access times are measured under nominal conditions of temperature, voltage, and horizontal orientation as measured on a representative sample of drives.
4. Access time = controller overhead + average seek time.
Access to data = controller overhead + average seek time + latency time.

4.2.2 Format command execution time for ≥ 512-byte sectors

		ST318451FC
Maximum (with verify)	60 minutes	
Maximum (without verify)	30 minutes	

4.2.3 General performance characteristics

Minimum sector interleave	1 to 1
Data buffer to/from disc media (one 512-byte logical block)*	
Minimum	37.4 MBytes/sec
Maximum	48.9 MBytes/sec
Fibre Channel Interface maximum instantaneous transfer rate	200 Mbytes/sec* per port (dual port = 400 Mbytes/sec*)
Logical block sizes	
Default is 512-byte data blocks	
Variable 512 to 704 bytes per sector in even number of bytes per sector. If n (number of bytes per sector) is odd, then n-1 will be used.	
Read/write consecutive sectors on a track	Yes
Flaw reallocation performance impact (for flaws reallocated at format time using the spare sectors per sparing zone reallocation scheme.)	Negligible
Overhead time for head switch in sequential mode	0.8 msec
Overhead time for one track cylinder switch in sequential mode	1.2 msec (typical)
Average rotational latency	2.0 msec

*Assumes no errors and no relocated logical blocks. Rate measured from the start of the first logical block transfer to or from the host.

4.3 Start/stop time

If the Motor Start option is disabled, the drive becomes ready within 20 seconds after DC power is applied. If a recoverable error condition is detected during the start sequence, the drive executes a recovery procedure and the time to become ready may exceed 30 seconds. Stop time is 30 seconds (maximum) from removal of DC power.

If the Motor Start option is enabled, the internal controller accepts the commands listed in the *Fibre Channel Interface Manual* less than 3 seconds after DC power has been applied. After the Motor Start command has been received, the drive becomes ready for normal operations within 20 seconds (excluding the error recovery procedure). The Motor Start command can also be used to command the drive to stop the spindle.

There is no power control switch on the drive.

4.4 Prefetch/multi-segmented cache control

The drive provides a prefetch (read look-ahead) and multi-segmented cache control algorithms that in many cases can enhance system performance. Cache refers to the drive buffer storage space when it is used in cache operations. To select this feature, the host sends the Mode Select command with the proper values in the applicable bytes in page 08h. Prefetch and cache operations are independent features from the standpoint that each is enabled and disabled independently using the Mode Select command; however, in actual operation, the prefetch feature overlaps cache operation somewhat as described in sections 4.5.1 and 4.5.2.

All default cache and prefetch mode parameter values (Mode Page 08h) for standard OEM versions of this drive family are given in Table 17.

4.5 Cache operation

Note. Refer to the *Fibre Channel Interface Manual* for more detail concerning the cache bits.

Of the 4,096 kbytes physical buffer space in the drive, 3,600 kbytes can be used as a cache. The buffer can be divided into logical segments (using Mode Select Page 08h, byte 13) from which data is read and to which data is written.

The drive keeps track of the logical block addresses of the data stored in each segment of the buffer. If the cache is enabled (see RCD bit in the *Fibre Channel Interface Manual*), data requested by the host with a read command is retrieved from the buffer, if possible, before any disc access is initiated. If cache operation is not enabled, the buffer (still segmented with the required number of segments) is still used, but only as circular buffer segments during disc medium read operations (disregarding Prefetch operation for the moment). That is, the drive does not check in the buffer segments for the requested read data, but goes directly to the medium to retrieve it. The retrieved data merely passes through some buffer segment on the way to the host. On a cache miss, all data transfers to the host are in accordance with buffer-full ratio rules. On a cache hit, the drive ignores the buffer-full ratio rules. See the explanation provided with the information about Mode Page 02h (disconnect/reconnect control) in the *Fibre Channel Interface Manual*.

The following is a simplified description of the prefetch/cache operation:

Case A—read command is received and the first logical block is already in the cache:

1. Drive transfers to the initiator the first logical block requested plus all subsequent contiguous logical blocks that are already in the cache. This data may be in multiple segments.
2. When a requested logical block is reached that is not in any cache segment, the drive fetches it and any remaining requested logical block addresses from the disc and puts them in a segment of the cache. The drive transfers the remaining requested logical blocks from the cache to the host in accordance with the Mode Select Disconnect/Reconnect parameters, page 02h.
3. If the prefetch feature is enabled, refer to section 4.5.2 for operation from this point.

Case B—A Read command requests data, and the first logical block is not in any segment of the cache:

1. The drive fetches the requested logical blocks from the disc and transfers them into a segment, and then from there to the host in accordance with the Mode Select Disconnect/Reconnect parameters, page 02h.
2. If the prefetch feature is enabled, refer to section 4.5.2 for operation from this point.

During a prefetch, the drive crosses a cylinder boundary to fetch data only if the Discontinuity (DISC) bit is set to 1 in bit 4 of byte 2 of the Mode Select parameters page 08h. Default is zero for bit 4.

Each cache segment is actually a self-contained circular buffer whose length is an integer number of logical blocks. The wrap-around capability of the individual segments greatly enhances the cache's overall performance, allowing a wide range of user-selectable configurations. The drive supports operation of any integer number of segments from 1 to 16. Divide the 3,600 Kbytes in the buffer by the number of segments to get the segment size. Default is 3 segments.

Note. The size of each segment is not reported by Mode Sense command page 08h, bytes 14 and 15. The value 0XFFFF is always reported regardless of the actual size of the segment. Sending a size specification using the Mode Select command (bytes 14 and 15) does not set up a new segment size. If the STRICT bit in Mode page 00h (byte 2, bit 1) is set to one, the drive responds as it does for any attempt to change an unchangeable parameter.

4.5.1 Caching write data

Write caching is a write operation by the drive that makes use of a drive buffer storage area where the data to be written to the medium is stored while the drive performs the Write command.

If read caching is enabled (RCD=0), then data written to the medium is retained in the cache to be made available for future read cache hits. The same buffer space and segmentation is used as set up for read functions. The buffer segmentation scheme is set up or changed independently, having nothing to do with the state of RCD. When a write command is issued, if RCD=0, the cache is first checked to see if any logical blocks that are to be written are already stored in the cache from a previous read or write command. If there are, the respective cache segments are cleared. The new data is cached for subsequent Read commands.

If the number of write data logical blocks exceed the size of the segment being written into, when the end of the segment is reached, the data is written into the beginning of the same cache segment, overwriting the data that was written there at the beginning of the operation; however, the drive does not overwrite data that has not yet been written to the medium.

If write caching is enabled (WCE=1), then the drive may return Good status on a write command after the data has been transferred into the cache, but before the data has been written to the medium. If an error occurs while writing the data to the medium, and Good status has already been returned, a deferred error will be generated.

The Synchronize Cache command may be used to force the drive to write all cached write data to the medium. Upon completion of a Synchronize Cache command, all data received from previous write commands will have been written to the medium.

Table 17 shows the mode default settings for the drive.

4.5.2 Prefetch operation

If the Prefetch feature is enabled, data in contiguous logical blocks on the disc immediately beyond that which was requested by a Read command are retrieved and stored in the buffer for immediate transfer from the buffer to the host on subsequent Read commands that request those logical blocks (this is true even if cache operation is disabled). Though the prefetch operation uses the buffer as a cache, finding the requested data in the buffer is a prefetch hit, not a cache operation hit.

To enable Prefetch, use Mode Select page 08h, byte 12, bit 5 (Disable Read Ahead - DRA bit). DRA bit = 0 enables prefetch.

Since data that is prefetched replaces data already in some buffer segments, the host can limit the amount of prefetch data to optimize system performance. The Max Prefetch field (bytes 8 and 9) limits the amount of prefetch. The drive does not use the Prefetch Ceiling field (bytes 10 and 11).

During a prefetch operation, the drive crosses a cylinder boundary to fetch more data only if Mode parameters page 08h, byte 2, bit 4 is set to 1 (Discontinuity--DISC bit).

When prefetch (read look-ahead) is enabled (enabled by DRA = 0), it operates under the control of ARLA (Adaptive Read Look-Ahead). If the host uses software interleave, ARLA enables prefetch of contiguous blocks from the disc when it senses that a prefetch hit will likely occur, even if two consecutive read operations were not for physically contiguous blocks of data (e.g. "software interleave"). ARLA disables prefetch when it decides that a prefetch hit will not likely occur. If the host is not using software interleave, and if two sequential read operations are not for contiguous blocks of data, ARLA disables prefetch, but as long as sequential read operations request contiguous blocks of data, ARLA keeps prefetch enabled.

5.0 Reliability specifications

The following reliability specifications assume correct host and drive operational interface, including all interface timings, power supply voltages, environmental requirements and drive mounting constraints.

Seek error rate:	Less than 10 errors in 10 ⁸ seeks
Read Error Rates ¹	
Recovered Data	Less than 10 errors in 10 ¹² bits transferred (OEM default settings)
Unrecovered Data	Less than 1 sector in 10 ¹⁵ bits transferred
Miscorrected Data	Less than 1 sector in 10 ²¹ bits transferred
Interface error rate:	Less than 1 error in 10 ¹² bits transferred with minimum receive eye. Less than 1 error in 10 ¹⁴ bits transferred with typical receive eye. See Section 9.6.4, "Differential PECL input." on page 58
MTBF:	1,200,000 hours
Preventive maintenance:	None required

1. Error rate specified with automatic retries and data correction with ECC enabled and all flaws reallocated.

5.1 Error rates

The error rates stated in this manual assume the following:

- The drive is operated in accordance with this manual using DC power as defined in paragraph 6.2, "DC power requirements."
- The drive has been formatted with the FC-AL Format command.
- Errors caused by media defects or host system failures are excluded from error rate computations.
- Assume random data.

5.1.0.1 Interface errors

An interface error is defined as a failure of the receiver on a port to recover the data as transmitted by the device port connected to the receiver. The error may be detected as a running disparity error, illegal code, loss of word sync, or CRC error. The total error rate for a loop of devices is the sum of the individual device error rates.

5.1.1 Environmental interference

When evaluating systems operation under conditions of electromagnetic interference (EMI), the performance of the drive within the system is considered acceptable if the drive does not generate an unrecoverable condition.

An unrecoverable error, or condition, is defined as one that:

- is not detected and corrected by the drive itself
- is not detected from the error or fault status provided through the drive or FC-AL interface
- is not recovered by normal drive or system recovery procedures without operator intervention

5.1.2 Write errors

Write errors can occur as a result of media defects, environmental interference, or equipment malfunction. Therefore, write errors are not predictable as a function of the number of bits passed.

If an unrecoverable write error occurs because of an equipment malfunction in the drive, the error is classified as a failure affecting MTBF. Unrecoverable write errors are those that cannot be corrected within two attempts at writing the record with a read verify after each attempt (excluding media defects).

5.1.3 Seek errors

A seek error is defined as a failure of the drive to position the heads to the addressed track. After detecting an initial seek error, the drive automatically performs an error recovery process. If the error recovery process fails, a seek positioning error (15h) is reported with a Medium error (3h) or Hardware error (4h) reported in the Sense Key. This is an unrecoverable seek error. Unrecoverable seek errors are classified as failures for MTBF

calculations. Refer to the *Fibre Channel Interface Manual*, part number 77767496, for Request Sense information.

5.2 Reliability and service

You can enhance the reliability of Cheetah X15 FC disc drives by ensuring that the drive receives adequate cooling. Section 6.0 provides recommended air-flow information, temperature measurements, and other information, which you can use to enhance the service life of the drive.

5.2.1 Mean time between failure (MTBF)

The production disc drive achieves an MTBF of 1,200,000 hours when operated in an environment that ensures the case temperatures specified in Section 6.4.1 are not exceeded. Short-term excursions up to the specification limits of the operating environment will not affect MTBF performance. Operating the drive at case temperatures above these values will adversely affect the drive's ability to meet specifications. See Section 6.4, "Environmental limits".

The MTBF target is specified as device power-on hours (POH) for all drives in service per failure.

The following expression defines MTBF:

$$\text{MTBF per measurement period} = \frac{\text{Estimated power-on operating hours in the period}}{\text{Number of drive failures in the period}}$$

Estimated power-on operating hours means power-on hours per disc drive times the total number of disc drives in service. Each disc drive must have accumulated at least nine months of operation. Data is calculated on a rolling average base for a minimum period of six months.

MTBF is based on the following assumptions:

- 8,760 power-on hours per year
- 250 average on/off cycles per year
- Operating at nominal voltages
- System provides adequate cooling to ensure the case temperatures specified in Section 6.4.1 are not exceeded.

Drive failure means any stoppage or failure to meet defined specifications caused by drive malfunction.

A S.M.A.R.T. predictive failure indicates that the drive is deteriorating to an imminent failure and is considered an MTBF hit.

5.2.2 Field failure rate vs time

The expected field failure rate is listed below. Drive utilization will vary. An estimate range of utilization is:

- 720 power-on hours (POH) per month
- 250 on/off cycles per year
- Read/seek/write operation 20% of POH
- System provides adequate cooling to ensure the case temperatures specified in Section 6.4.1 are not exceeded.

Month Parts per million (PPM)

1	2,364
2	1,422
3	1,403
4	1,391
5	1,317
6	1,255
7	1,162

Failure rate is calculated as follows:

- No system-induced failures counted
- Based on 1,200,000 MTBF and 720 POH per month
- Month 1's rate includes a 300 PPM installation failure

5.2.3 Preventive maintenance

No routine scheduled preventive maintenance is required.

5.2.4 Service life

Depot repair or replacement of major parts is permitted during the service lifetime.

5.2.5 Service philosophy

Special equipment is required to repair the drive HDA. Repairs must be performed only at a properly equipped and staffed Seagate service and repair facility. Troubleshooting and repair of PCBs in the field is not recommended because of the extensive diagnostic equipment required for effective servicing. There are not spare parts available for this drive. The drive warranty is voided if the HDA is opened.

5.2.6 Service tools

No special tools are required for site installation or recommended for site maintenance. Refer to Section 5.2.5. The depot repair philosophy of the drive precludes the necessity for special tools. Field repair of the drive is not practical because users cannot purchase individual parts for the drive.

5.2.7 Hot plugging the drive

Inserting and removing the drive on the FC-AL will interrupt loop operation. The interruption occurs when the receiver of the next device in the loop must synchronize to a different input signal. FC error detection mechanisms, character sync, running disparity, word sync, and CRC are able to detect any error. Recovery is initiated based on the type of error.

The disc drive defaults to the FC-AL Monitoring state, Pass-through state, when it is powered-on by switching the power or hot plugged. The control line to an optional port bypass circuit (external to the drive), defaults to the Enable Bypass state. If the bypass circuit is present, the next device in the loop will continue to receive the output of the previous device to the newly inserted device. If the bypass circuit is not present, loop operation is temporarily disrupted until the next device starts receiving the output from the newly inserted device and regains synchronization to the new input.

The Pass-through state is disabled while the drive performs self test of the FC interface. The control line for an external port bypass circuit remains in the Enable Bypass state while self test is running. If the bypass circuit is present, loop operation may continue. If the bypass circuit is not present, loop operation will be halted while the self test of the FC interface runs.

When the self test completes successfully, the control line to the bypass circuit is disabled and the drive enters the FC-AL Initializing state. The receiver on the next device in the loop must synchronize to output of the newly inserted drive.

If the self-test fails, the control line to the bypass circuit remains in the Enable Bypass state.

Note. It is the responsibility of the systems integrator to assure that no temperature, energy, voltage hazard, or ESD potential hazard is presented during the hot connect/disconnect operation. Discharge the static electricity from the drive carrier prior to inserting it into the system.

Caution. The drive motor must come to a complete stop prior to changing the plane of operation. This time is required to insure data integrity.

5.2.8 S.M.A.R.T.

S.M.A.R.T. is an acronym for Self-Monitoring Analysis and Reporting Technology. This technology is intended to recognize conditions that indicate imminent drive failure and is designed to provide sufficient warning of a failure to allow you to back up the data before an actual failure occurs.

Note. The drive's firmware monitors specific attributes for degradation over time but can't predict instantaneous drive failures.

Each monitored attribute has been selected to monitor a specific set of failure conditions in the operating performance of the drive and the thresholds are optimized to minimize "false" and "failed" predictions.

Controlling S.M.A.R.T.

The operating mode of S.M.A.R.T. is controlled by the DEXCPT and PERF bits on the Informational Exceptions Control mode page (1Ch). Use the DEXCPT bit to enable or disable the S.M.A.R.T. feature. Setting the DEXCPT bit disables all S.M.A.R.T. functions. When enabled, S.M.A.R.T. collects on-line data as the drive performs normal read and write operations. When the PERF bit is set, the drive is considered to be in "On-line Mode Only" and will not perform off-line functions.

You can measure off-line attributes and force the drive to save the data by using the Rezero Unit command. Forcing S.M.A.R.T. resets the timer so that the next scheduled interrupt is in two hours.

You can interrogate the drive through the host to determine the time remaining before the next scheduled measurement and data logging process occurs. To accomplish this, issue a Log Sense command to log page 0x3E. This allows you to control when S.M.A.R.T. interruptions occur. Forcing S.M.A.R.T. with the RTZ command resets the timer.

Performance impact

S.M.A.R.T. attribute data is saved to the disc so that the events that caused a predictive failure can be recreated. The drive measures and saves parameters once every two hours subject to an idle period on the FC-AL bus. The process of measuring off-line attribute data and saving data to the disc is uninterruptable. The maximum on-line only processing delay is summarized below:

Maximum processing delay

	On-line only delay DEXCPT = 0, PERF = 1	Fully-enabled delay DEXCPT = 0, PERF = 0
S.M.A.R.T. delay times	50 milliseconds	300 milliseconds

Reporting control

Reporting is controlled by the MRIE bits in the Informational Exceptions Control mode page (1Ch). Subject to the reporting method, the firmware will issue to the host an 01-5Dxx sense code. The error code is preserved through bus resets and power cycles.

Determining rate

S.M.A.R.T. monitors the rate at which errors occur and signals a predictive failure if the rate of degraded errors increases to an unacceptable level. To determine rate, error events are logged and compared to the number of total operations for a given attribute. The interval defines the number of operations over which to measure the rate. The counter that keeps track of the current number of operations is referred to as the Interval Counter.

S.M.A.R.T. measures error rates. All errors for each monitored attribute are recorded. A counter keeps track of the number of errors for the current interval. This counter is referred to as the Failure Counter.

Error rate is the number of errors per operation. The algorithm that S.M.A.R.T. uses to record rates of error is to set thresholds for the number of errors and their interval. If the number of errors exceeds the threshold before the interval expires, the error rate is considered to be unacceptable. If the number of errors does not exceed the threshold before the interval expires, the error rate is considered to be acceptable. In either case, the interval and failure counters are reset and the process starts over.

Predictive failures

S.M.A.R.T. signals predictive failures when the drive is performing unacceptably for a period of time. The firmware keeps a running count of the number of times the error rate for each attribute is unacceptable. To accomplish this, a counter is incremented each time the error rate is unacceptable and decremented (not to exceed zero) whenever the error rate is acceptable. If the counter continually increments such that it reaches the pre-

dictive threshold, a predictive failure is signaled. This counter is referred to as the Failure History Counter. There is a separate Failure History Counter for each attribute.

5.2.9 Thermal Monitor

Cheetah X15 FC drives implement a temperature warning system which:

1. Signals the host if the temperature exceeds a value which would threaten the drive.
2. Signals the host if the temperature exceeds a user-specified value.
3. Saves a S.M.A.R.T. data frame on the drive which exceeds the threatening temperature value.

A temperature sensor monitors the drive temperature and issues a warning over the interface when the temperature exceeds a set threshold. The temperature is measured at power-up and then at ten-minute intervals after power-up.

The thermal monitor system generates a warning code of 01-0B01 when the temperature exceeds the specified limit in compliance with the SCSI standard. The drive temperature is reported in the FRU code field of mode sense data. You can use this information to determine if the warning is due to the temperature exceeding the drive threatening temperature or the user-specified temperature.

This feature is controlled by the Enable Warning (EWasc) bit, and the reporting mechanism is controlled by the Method of Reporting Informational Exceptions field (MRIE) on the Informational Exceptions Control (IEC) mode page (1Ch).

The current algorithm implements two temperature trip points. The first trip point is set at 65°C which is the maximum temperature limit according to the drive specification. The second trip point is user-selectable using the Log Select command. The reference temperature parameter in the temperature log page (see Table 1) can be used to set this trip point. The default value for this drive is 65°C, however, you can set it to any value in the range of 0 to 65°C. If you specify a temperature greater than 65°C in this field, the temperature is rounded down to 65°C. A sense code is sent to the host to indicate the rounding of the parameter field.

Table 1: Temperature Log Page (0Dh)

Parameter Code	Description
0000h	Primary Temperature
0001h	Reference Temperature

5.2.10 Drive Self Test (DST)

Drive Self Test (DST) is a technology designed to recognize drive fault conditions that qualify the drive as a failed unit. DST validates the functionality of the drive at a system level.

There are two test coverage options implemented in DST:

1. Extended test
2. Short test

The most thorough option is the extended test that performs various tests on the drive and scans every logical block address (LBA) of the drive. The short test is time-restricted and limited in length—it does not scan the entire media surface, but does some fundamental tests and scans portions of the media.

If DST encounters an error during either of these tests, it reports a fault condition. If the drive fails the test, remove it from service and return it to Seagate for service.

5.2.10.1 DST Failure Definition

The drive will present a “diagnostic failed” condition through the self-tests results value of the diagnostic log page if a functional failure is encountered during DST. The channel and servo parameters are not modified to test the drive more stringently, and the number of retries are not reduced. All retries and recovery processes are enabled during the test. If data is recoverable, no failure condition will be reported regardless of the number of retries required to recover the data.

The following conditions are considered DST failure conditions:

- Seek error after retries are exhausted
- Track-follow error after retries are exhausted
- Read error after retries are exhausted
- Write error after retries are exhausted.

Recovered errors will not be reported as diagnostic failures.

5.2.10.2 Implementation

This section provides all of the information necessary to implement the DST function on this drive.

5.2.10.2.1 State of the drive prior to testing

The drive must be in a ready state before issuing the Send Diagnostic command. There are multiple reasons why a drive may not be ready, some of which are valid conditions, and not errors. For example, a drive may be in process of doing a format, or another DST. It is the responsibility of the host application to determine the “not ready” cause.

While not technically part of DST, a Not Ready condition also qualifies the drive to be returned to Seagate as a failed drive.

A Drive Not Ready condition is reported by the drive under the following conditions:

- Motor will not spin
- Motor will not lock to speed
- Servo will not lock on track
- Drive cannot read configuration tables from the disc

In these conditions, the drive responds to a Test Unit Ready command with an 02/04/00 or 02/04/03 code.

5.2.10.2.2 Invoking DST

To invoke DST, submit the Send Diagnostic command with the appropriate Function Code (001b for the short test or 010b for the extended test) in bytes 1, bits 5, 6, and 7. Refer to the Seagate SCSI Interface Manual, Volume 3, part number 75789509 for additional information about invoking DST.

5.2.10.2.3 Short and extended tests

DST has two testing options:

1. short
2. extended

These testing options are described in the following two subsections.

Each test consists of three segments: an electrical test segment, a servo test segment, and a read/verify scan segment.

Short test (Function Code: 001b)

The purpose of the short test is to provide a time-limited test that tests as much of the drive as possible within 120 seconds. The short test does not scan the entire media surface, but does some fundamental tests and scans portions of the media. A complete read/verify scan is not performed and only factual failures will report a fault condition. This option provides a quick confidence test of the drive.

Extended test (Function Code: 010b)

The objective of the extended test option is to empirically test critical drive components. For example, the seek tests and on-track operations test the positioning mechanism. The read operation tests the read head element and the media surface. The write element is tested through read/write/read operations. The integrity of the media is checked through a read/verify scan of the media. Motor functionality is tested by default as a part of these tests.

The anticipated length of the Extended test is reported through the Control Mode page.

5.2.10.2.4 Log page entries

When the drive begins DST, it creates a new entry in the Self-test Results Log page. The new entry is created by inserting a new self-test parameter block at the beginning of the self-test results log parameter section of the log page. Existing data will be moved to make room for the new parameter block. The drive reports 20 parameter blocks in the log page. If there are more than 20 parameter blocks, the least recent parameter block will be deleted. The new parameter block will be initialized as follows:

1. The Function Code field is set to the same value as sent in the DST command
2. The Self-Test Results Value field is set to Fh
3. The drive will store the log page to non-volatile memory

After a self-test is complete or has been aborted, the drive updates the Self-Test Results Value field in its Self-Test Results Log page in non-volatile memory. The host may use Log Sense to read the results from up to the last 20 self-tests performed by the drive. The self-test results value is a 4-bit field that reports the results of the test. If the field is zero, the drive passed with no errors detected by the DST. If the field is not zero, the test failed for the reason reported in the field.

The drive will report the failure condition and LBA (if applicable) in the Self-test Results Log parameter. The Sense key, ASC, ASCQ, and FRU are used to report the failure condition.

5.2.10.2.5 Abort

There are several ways to abort a diagnostic. You can use a SCSI Bus Reset or a Bus Device Reset message to abort the diagnostic.

You can abort a DST executing in background mode by using the abort code in the DST Function Code field. This will cause a 01 (self-test aborted by the application client) code to appear in the self-test results values log. All other abort mechanisms will be reported as a 02 (self-test routine was interrupted by a reset condition).

5.2.11 Product warranty

Beginning on the date of shipment to the customer and continuing for the period specified in your purchase contract, Seagate warrants that each product (including components and subassemblies) that fails to function properly under normal use due to defect in materials or workmanship or due to nonconformance to the applicable specifications will be repaired or replaced, at Seagate's option and at no charge to the customer, if returned by customer at customer's expense to Seagate's designated facility in accordance with Seagate's warranty procedure. Seagate will pay for transporting the repair or replacement item to the customer. For more detailed warranty information, refer to the standard terms and conditions of purchase for Seagate products on your purchase documentation.

The remaining warranty for a particular drive can be determined by calling Seagate Customer Service at 1-800-468-3472. You can also determine remaining warranty using the Seagate web site (www.seagate.com). The drive serial number is required to determine remaining warranty information.

Shipping

When transporting or shipping a drive, use only a Seagate-approved container. Keep your original box. Seagate approved containers are easily identified by the Seagate Approved Package label. Shipping a drive in a non-approved container voids the drive warranty.

Seagate repair centers may refuse receipt of components improperly packaged or obviously damaged in transit. Contact your authorized Seagate distributor to purchase additional boxes. Seagate recommends shipping by an air-ride carrier experienced in handling computer equipment.

Product repair and return information

Seagate customer service centers are the only facilities authorized to service Seagate drives. Seagate does not sanction any third-party repair facilities. Any unauthorized repair or tampering with the factory seal voids the warranty.

6.0 Physical/electrical specifications

This section provides information relating to the physical and electrical characteristics of the drive.

6.1 AC power requirements

None.

6.2 DC power requirements

The voltage and current requirements for a single drive are shown below. Values indicated apply at the drive connector.

Table 2: DC power requirements

	Notes	ST318451FC	
		(Amps)	(Amps)
Voltage		+5V	+12V [2]
Regulation	[5]	±5%	±5% [2]
Avg idle current DC \bar{X}	[1] [7]	0.73	0.71
Maximum starting current			
(peak DC) DC	3 σ [3]	0.78	1.4
(peak AC) AC	3 σ [3]	1.04	3.7
Delayed motor start (max) DC	3 σ [1] [4]	0.63	0.03
Peak operating current:			
Typical DC \bar{X}	[1] [6]	0.77	1.15
Maximum DC	3 σ [1]	0.78	1.26
Maximum (peak) DC	3 σ	1.17	2.49

- [1] Measured with average reading DC ammeter. Instantaneous +12V current peaks will exceed these values. Power supply at nominal voltage. N = 6, 22 Degrees C ambient.
- [2] For +12 V, a –10% tolerance is allowed during initial spindle start but must return to ±5% before reaching 14,904 RPM. The ±5% must be maintained after the drive signifies that its power-up sequence has been completed and that the drive is able to accept selection by the host initiator.
- [3] See +12V current profile in Figure 3.
- [4] This condition occurs when the Motor Start option is enabled and the drive has not yet received a Start Motor command.
- [5] See paragraph 6.2.1, "Conducted noise immunity." Specified voltage tolerance includes ripple, noise, and transient response.
- [6] Operating condition is defined as random 8 block reads at 266 I/Os per second. Current and power specified at nominal voltages. Decreasing +5 volt supply by 5% increases 5 volt current by 3.2%. Decreasing +12 volt supply by 5% increases 12 volt current by 2.1%.
- [7] During idle, the drive heads are relocated every 60 seconds to a random location within the band from three-quarters to maximum track.

General DC power requirement notes.

1. Minimum current loading for each supply voltage is not less than 2.3% of the maximum operating current shown.
2. The +5V and +12V supplies should employ separate ground returns.
3. Where power is provided to multiple drives from a common supply, careful consideration for individual drive power requirements should be noted. Where multiple units are powered on simultaneously, the peak starting current must be available to each device.
4. Parameters, other than spindle start, are measured after a 10-minute warm up.
5. No terminator power.

6.2.1 Conducted noise immunity

Noise is specified as a periodic and random distribution of frequencies covering a band from DC to 10 MHz. Maximum allowed noise values given below are peak-to-peak measurements and apply at the drive power connector.

	+5V	+12V (with spindle motor not running)
0 to 100 kHz	150mV	150mV
100 kHz to 10 MHz	100mV	100mV

6.2.2 Power sequencing

The drive does not require power sequencing. The drive protects against inadvertent writing during power-up and down.

6.2.3 Current profiles

Figure 3 identifies the drive +12V current profile. The current during the various times is as shown:

- T0 Power is applied to the drive.
- T1 Controller self-tests are performed.
- T2 Spindle begins to accelerate under current limiting after performing internal diagnostics.
- T3 Spindle is up to speed and the Head-Arm restraint is unlocked.

Note: All times and currents are typical. See Table 2 for maximum current requirements.

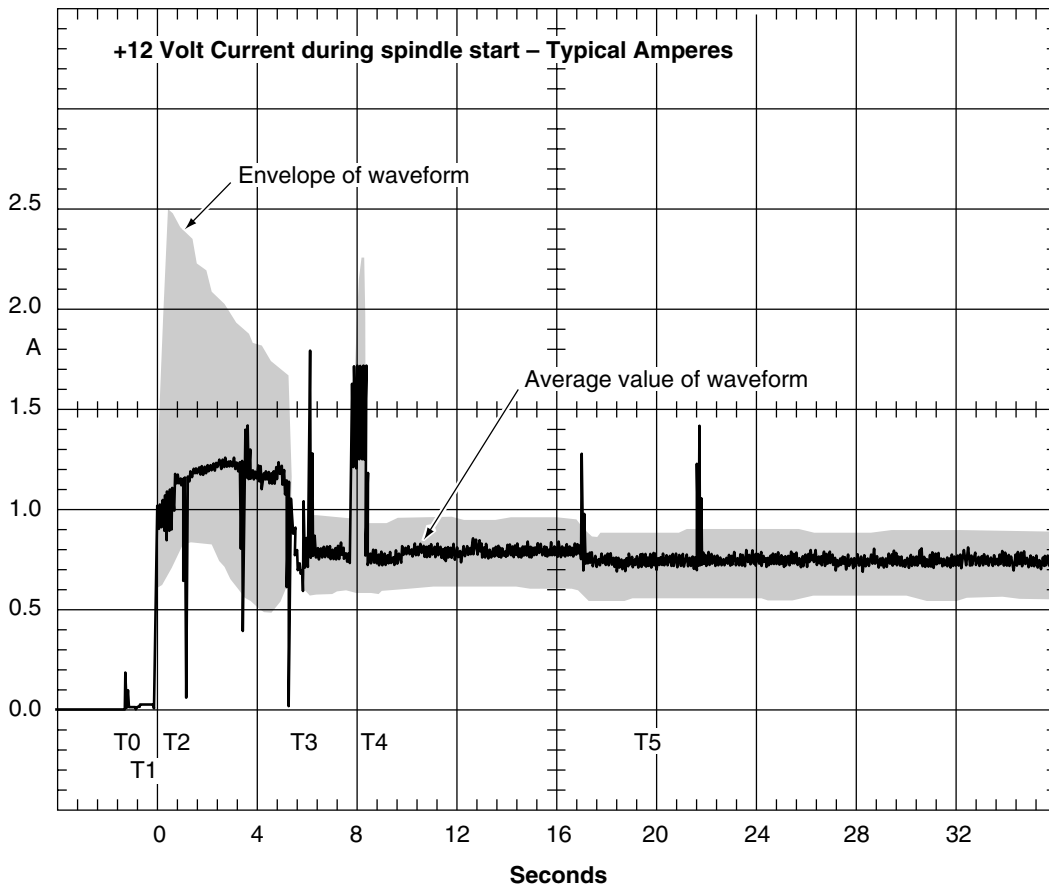

Figure 3. Typical ST318451FC drive +12V current profile

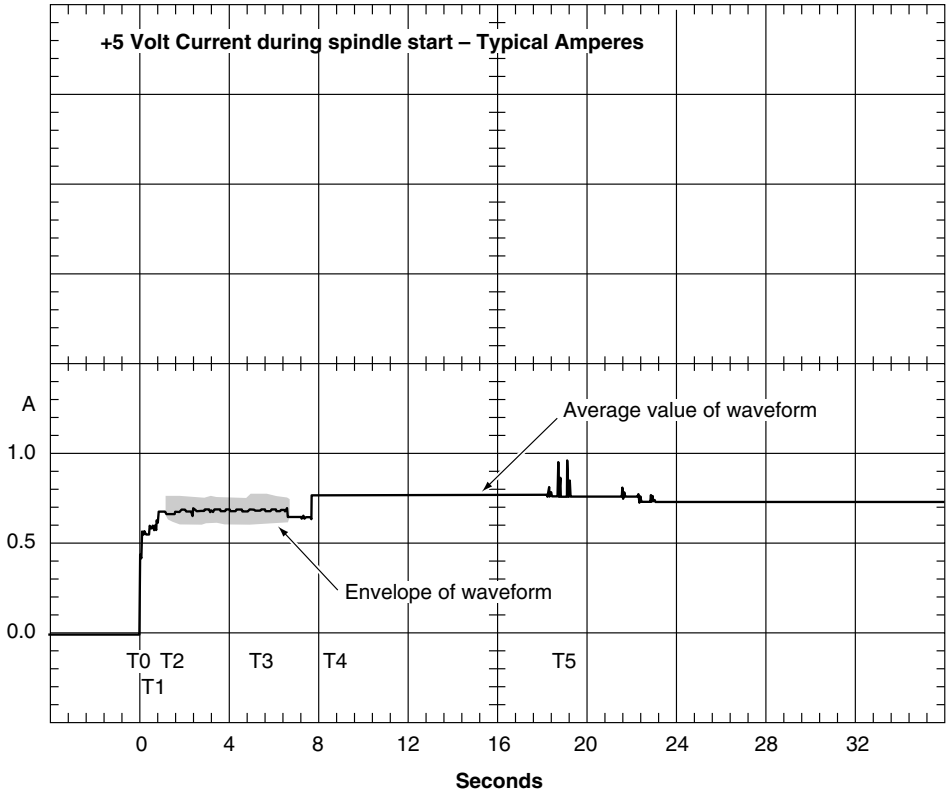

Figure 4. Typical ST318451FC drive +5V current profile

6.3 Power dissipation

Typical power dissipation under idle conditions is 12.71 watts (41.53 BTUs per hour).

To obtain operating power for typical random read operations, refer to the following I/O rate curve (see Figure 5). Locate the typical I/O rate for a drive in your system on the horizontal axis and read the corresponding +5 volt current, +12 volt current, and total watts on the vertical axis. To calculate BTUs per hour, multiply watts by 3.4123.

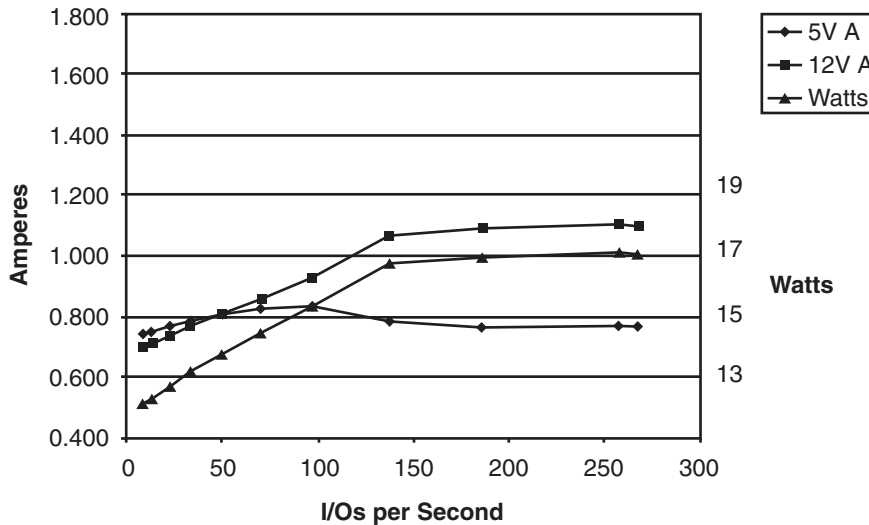

Figure 5. DC current and power vs. input/output operations per second

6.4 Environmental limits

Temperature and humidity values experienced by the drive must be such that condensation does not occur on any drive part. Altitude and atmospheric pressure specifications are referenced to a standard day at 58.7°F (14.8°C). Maximum wet bulb temperature is 82°F (28°C).

6.4.1 Temperature

a. Operating

With cooling designed to maintain the case temperatures of Table 3, the drive meets all specifications over a 41°F to 131°F (5°C to 55°C) drive ambient temperature range with a maximum temperature gradient of 36°F (20°C) per hour. The enclosure for the drive should be designed such that the temperatures at the locations specified in Table 3 are not exceeded. Air flow may be needed to achieve these temperature values (see Section 8.4 and 8.4.1). Operation at case temperatures above these values may adversely affect the drives ability to meet specifications.

The MTBF specification for the drive is based on operating in an environment that ensures that the case temperatures specified in Table 3 are not exceeded. Occasional excursions to drive ambient temperatures of 131°F (55°C) or 41°F (5°C) may occur without impact to specified MTBF. Air flow may be needed to achieve these temperatures (see Section 8.4.1). Continual or sustained operation at case temperatures above these values may degrade MTBF.

To confirm that the required cooling for the electronics and HDA is provided, place the drive in its final mechanical configuration, perform random write/read operations. After the temperatures stabilize, measure the case temperature of the components listed in Table 3 (see note [2]).

The maximum allowable HDA case temperature is 60°C. Operation of the drive at the maximum case temperature is intended for short time periods only. Continuous operation at the elevated temperatures will reduce product reliability.

Table 3: PCBA and HDA temperatures

Items in Figure 6	Maximum allowable case temperature (°C) operating	Maximum allowable case [3] temperatures (°C) to meet MTBF spec.
HDA [2]	65	50
1 (Processor)	77	57
2 (A/D Demod)	77	57
3 (FC Interface)	102	82
4 (Motor Driver)	87	67

Notes.

- [1] Section 8.3.1 describes the air-flow patterns used when generating the 1,200,000 hours MTBF guidelines in column 2. Air flow was opposite that shown in Section 8.4. Local air velocity was 0.92 m/sec (180 lfm). Inlet air temperature to the drive was 77°F (25°C), plus 9°F (5°C) temperature rise in the test enclosure (86°F/30°C ambient local to the drive).
- [2] Measure HDA temp at point labeled “HDA” on Figure 6.
- [3] PCB mounted integrated circuit case.

b. Non-operating

–40° to 158°F (–40° to 70°C) package ambient with a maximum gradient of 36°F (20°C) per hour. This specification assumes that the drive is packaged in the shipping container designed by Seagate for use with drive.

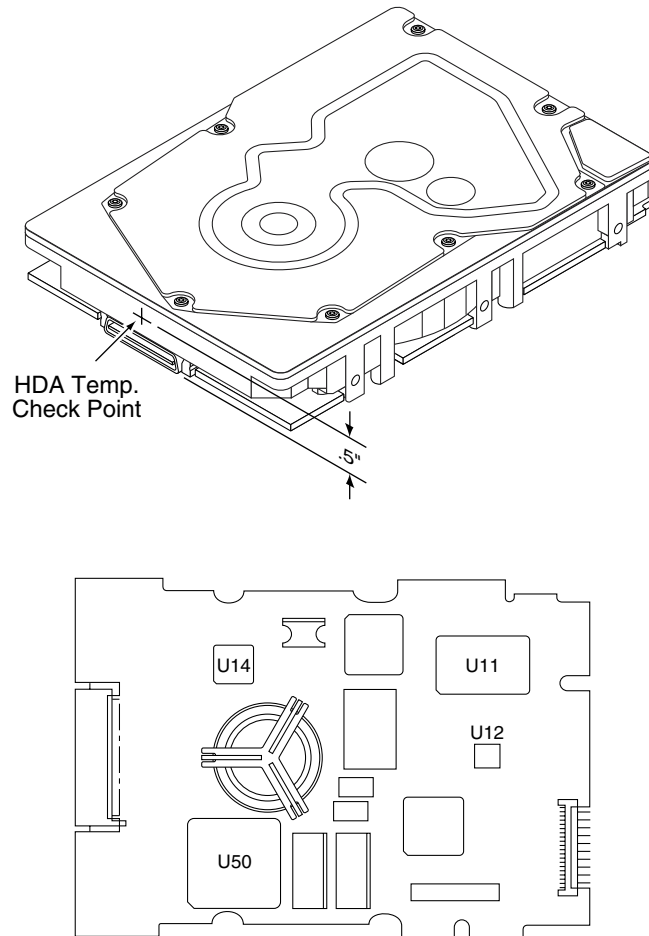

Figure 6. Locations of PCBA components listed in Table 3

6.4.2 Relative humidity

The values below assume that no condensation on the drive occurs.

a. Operating

5% to 95% non-condensing relative humidity with a maximum gradient of 10% per hour.

b. Non-operating

5% to 95% non-condensing relative humidity.

6.4.3 Effective altitude (sea level)

a. Operating

–1,000 to +10,000 feet (–305 to +3,048 meters)

b. Non-operating

–1,000 to +40,000 feet (–305 to +12,210 meters)

6.4.4 Shock and vibration

Shock and vibration limits specified in this document are measured directly on the drive chassis. If the drive is installed in an enclosure to which the stated shock and/or vibration criteria is applied, resonances may occur internally to the enclosure resulting in drive movement in excess of the stated limits. If this situation is apparent, it may be necessary to modify the enclosure to minimize drive movement.

The limits of shock and vibration defined within this document are specified with the drive mounted by any of the four methods shown in Figure 7, and in accordance with the restrictions of Section 8.5. Orientation of the side nearest the LED may be up or down.

6.4.4.1 Shock

a. Operating—normal

The drive, as installed for normal operation, shall operate error free while subjected to intermittent shock not exceeding 15.0 Gs at a maximum duration of 11 msec (half sinewave). The drive, as installed for normal operation, shall operate error free while subjected to intermittent shock not exceeding 65.0 Gs at a maximum duration of 2 msec (half sinewave). Shock may be applied in the X, Y, or Z axis.

b. Operating—abnormal

Equipment, as installed for normal operation, does not incur physical damage while subjected to intermittent shock not exceeding 40 Gs at a maximum duration of 11 msec (half sinewave). Shock occurring at abnormal levels may promote degraded operational performance during the abnormal shock period. Specified operational performance will continue when normal operating shock levels resume. Shock may be applied in the X, Y, or Z axis. Shock is not to be repeated more than two times per second.

c. Non-operating

The limits of non-operating shock shall apply to all conditions of handling and transportation. This includes both isolated drives and integrated drives.

The drive subjected to nonrepetitive shock not exceeding 75 Gs at a maximum duration of 11 msec (half sinewave) shall not exhibit device damage or performance degradation. Shock may be applied in the X, Y, or Z axis.

The drive subjected to nonrepetitive shock not exceeding 250 Gs at a maximum duration of 2 msec (half sinewave) does not exhibit device damage or performance degradation. Shock may be applied in the X, Y, or Z axis.

The drive subjected to nonrepetitive shock not exceeding 125 Gs at a maximum duration of 0.5 msec (half sinewave) does not exhibit device damage or performance degradation. Shock may be applied in the X, Y, or Z axis.

d. Packaged

Disc drives shipped as loose load (not palletized) general freight will be packaged to withstand drops from heights as defined in the table below. For additional details refer to Seagate specifications 30190-001 (under 100 lbs/45 kg) or 30191-001 (over 100 lbs/45 Kg).

Package size	Packaged/product weight	Drop height
<600 cu in (<9,800 cu cm)	Any	60 in (1524 mm)
600-1800 cu in (9,800-19,700 cu cm)	0-20 lb (0 to 9.1 kg)	48 in (1219 mm)
>1800 cu in (>19,700 cu cm)	0-20 lb (0 to 9.1 kg)	42 in (1067 mm)
>600 cu in (>9,800 cu cm)	20-40 lb (9.1 to 18.1 kg)	36 in (914 mm)

Drives packaged in single or multipacks with a gross weight of 20 pounds (8.95 kg) or less by Seagate for general freight shipment shall withstand a drop test from 48 inches (1,070 mm) against a concrete floor or equivalent.

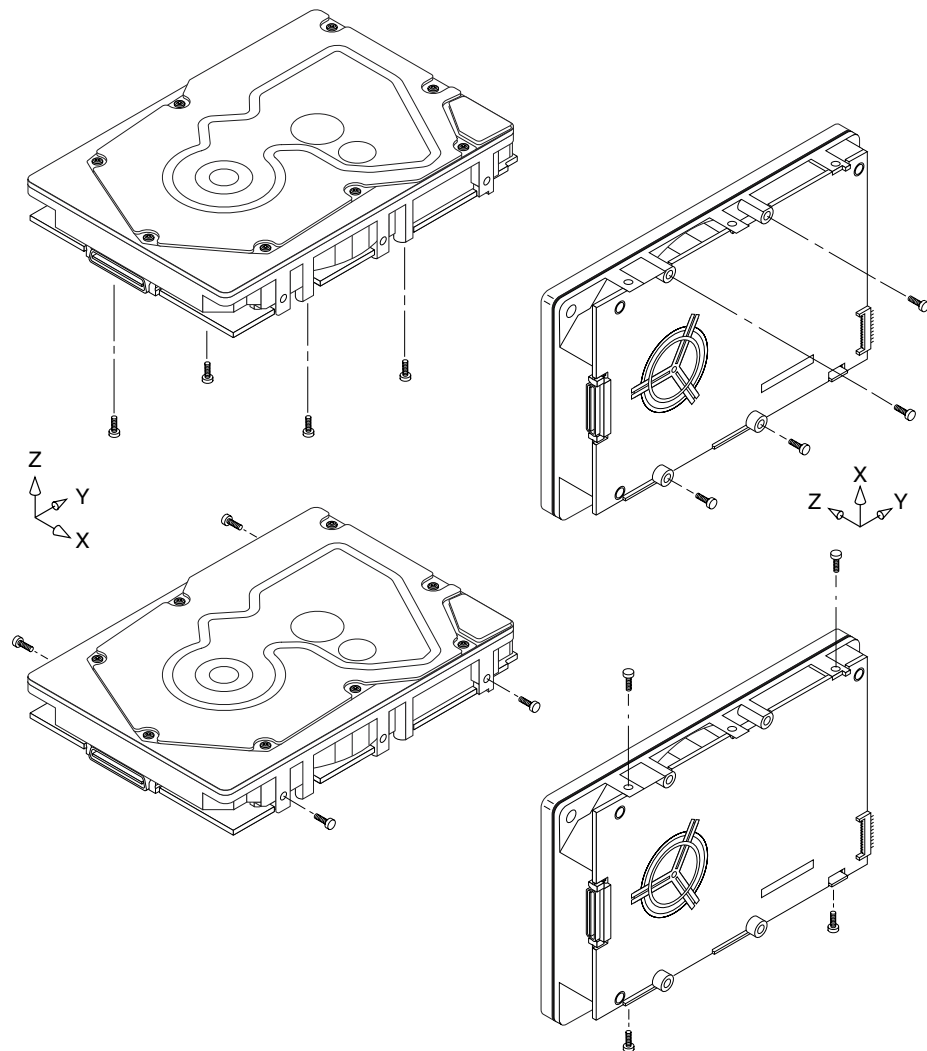

Figure 7. Recommended mounting

6.4.4.2 Vibration

a. Operating—normal

The drive as installed for normal operation, shall comply with the complete specified performance while subjected to continuous vibration not exceeding

5-500 Hz @ 0.5 G (zero to peak)

Vibration may be applied in the X, Y, or Z axis.

Operating normal translational random flat profile

10 - 400 Hz 0.4 GRMS

b. Operating—abnormal

Equipment as installed for normal operation shall not incur physical damage while subjected to periodic vibration not exceeding:

15 minutes of duration at major resonant frequency

5-500 Hz @ 0.75 G (X, Y, or Z axis)

Vibration occurring at these levels may degrade operational performance during the abnormal vibration period. Specified operational performance will continue when normal operating vibration levels are resumed. This assumes system recovery routines are available.

Operating abnormal translational random flat profile

10 - 400 Hz 1.2 GRMS

c. Non-operating

The limits of non-operating vibration shall apply to all conditions of handling and transportation. This includes both isolated drives and integrated drives.

The drive shall not incur physical damage or degraded performance as a result of continuous vibration not exceeding

5-22 Hz @ 0.040 inches (1.02 mm) displacement (zero to peak)

22-500 Hz @ 2.00 G

Vibration may be applied in the X, Y, or Z axis.

Non-operating translational random flat profile

10 - 400 Hz 1.2 GRMS

6.4.5 Air cleanliness

The drive is designed to operate in a typical office environment with minimal environmental control.

6.4.6 Acoustics

Sound power during idle mode shall be 4.0 bels typical when measured to ISO 7779 specification.

There will not be any discrete tones more than 10 dB above the masking noise on typical drives when measured according to Seagate specification 30553-001. There will not be any tones more than 24 dB above the masking noise on any drive.

6.4.7 Electromagnetic susceptibility

See Section 2.1.1.1.

6.5 Mechanical specifications

The following nominal dimensions are exclusive of the decorative front panel accessory. However, dimensions of the front panel are shown in figure below. Refer to Figure 8 for detailed mounting configuration dimensions. See Section 8.5, “Drive mounting.”

Height:	1.000 in	25.4 mm
Width:	4.000 in	101.6 mm
Depth:	5.75 in	146.05 mm
Weight:	1.6 pounds	0.726 kilograms

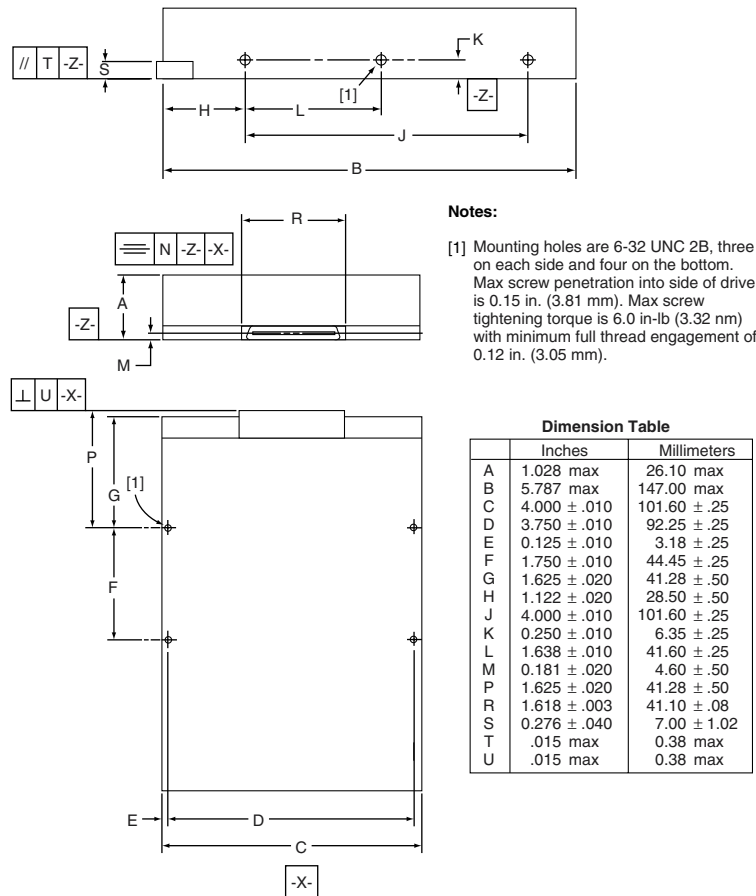

Figure 8. Mounting configuration dimensions

7.0 Defect and error management

The drive, as delivered, complies with this product manual. The read error rates and specified storage capacities are not dependent upon use of defect management routines by the host (initiator).

Defect and error management in the SCSI protocol involves the drive internal defect/error management and FC-AL system error considerations (errors in communications between the initiator and the drive). Tools for use in designing a defect/error management plan are briefly outlined in this section. References to other sections are provided when necessary.

7.1 Drive internal defects/errors

During the initial drive format operation at the factory, media defects are identified, tagged as being unusable, and their locations recorded on the drive primary defects list (referred to as the “P” list and also as the ETF defect list). At factory format time, these known defects are also reallocated, that is, reassigned to a new place on the medium and the location listed in the defects reallocation table. The “P” list is not altered after factory formatting. Locations of defects found and reallocated during error recovery procedures after drive shipment are listed in the “G” list (defects growth list). The “P” and “G” lists may be referenced by the initiator using the Read Defect Data command.

Details of the SCSI commands supported by the drive are described in the *Fibre Channel Interface Manual*. Also, more information on the drive Error Recovery philosophy is presented in the *Fibre Channel Interface Manual*.

7.2 Drive error recovery procedures

When an error occurs during drive operation, the drive, if programmed to do so, performs error recovery procedures to attempt to recover the data. The error recovery procedures used depend on the options previously set in the Error Recovery Parameters mode page. Error recovery and defect management may involve using several SCSI commands described in the *Fibre Channel Interface Manual*. The drive implements selectable error recovery time limits required in video applications.

The error recovery scheme supported by the drive provides a way to control the total error recovery time for the entire command in addition to controlling the recovery level for a single LBA. The total amount of time spent in error recovery for a command can be limited using the Recovery Time Limit bytes in the Error Recovery mode page. The total amount of time spent in error recovery for a single LBA can be limited using the Read Retry Count or Write Retry Count bytes in the Error Recovery mode page.

The drive firmware error recovery algorithms consists of 11 levels for read recoveries and five levels for write. Each level may consist of multiple steps, where a step is defined as a recovery function involving a single re-read or re-write attempt. The maximum level used by the drive in LBA recovery is determined by the read and write retry counts.

Table 4 equates the read and write retry count with the maximum possible recovery time for read and write recovery of individual LBAs. The times given do not include time taken to perform reallocations. Reallocations are performed when the ARRE bit (for reads) or AWRE bit (for writes) is one, the RC bit is zero, and the recovery time limit for the command has not yet been met. Time needed to perform reallocation is not counted against the recovery time limit.

When the RC bit is one, reallocations are disabled even if the ARRE or AWRE bits are one. The drive will still perform data recovery actions within the limits defined by the Read Retry Count, Write Retry Count, and Recovery Time Limit parameters. However, the drive does not report any unrecovered errors.

Table 4: Read and write retry count maximum recovery times

Read retry count ¹	Maximum recovery time per LBA (cumulative, msec)	Write retry count ¹	Maximum recovery time per LBA (cumulative, msec)
0	52.4	0	24.2
1	60.4	1	36.3
2	205.5	2	40.3
3	221.6	3	52.4
4	253.7	4	129.0
5	286.0	5 (default)	157.2
6	350.4		
7	451.1		
8	467.2		
9	503.5		
10	552.4		
11 (default)	1,245.3		

- [1] Setting these retry counts to a value below the default setting could result in degradation of the unrecovered error rate. For example, suppose the read/write recovery page has the RC bit = 0, the read retry count set to 4, and the recovery time limit set to 450. A 4-block read command can take up to 253.7 msec recovery time for each block and a maximum of 450 msec recovery for all four blocks. If either of these limits is reached and a block has not yet been recovered, the command will end with Check Condition status and an unrecoverable read error will be reported.

7.3 FC-AL system errors

Information on the reporting of operational errors or faults across the interface is given in the *Fibre Channel Interface Manual*. The FCP Response returns information to the host about numerous kinds of errors or faults. The Receive Diagnostic Results reports the results of diagnostic operations performed by the drive.

Status returned by the drive to the initiator is described in the *Fibre Channel Interface Manual*. Status reporting plays a role in systems error management and its use in that respect is described in sections where the various commands are discussed.

8.0 Installation

Cheetah X15 FC disc drive installation is a plug-and-play process. There are no jumpers, switches, or terminators on the drive. Simply plug the drive into the host's 40-pin Fibre Channel backpanel connector (FC-SCA)—no cables are required. See Section 9.5 for additional information about this connector.

Use the FC-AL interface to select drive ID and all option configurations for devices on the loop.

If multiple devices are on the same FC-AL and physical addresses are used, set the device selection IDs (SEL IDs) on the backpanel so that no two devices have the same selection ID. This is called the hard assigned arbitrated loop physical address (AL_PA). There are 125 AL_PAs available (see Table 24). If you set the AL_PA on the backpanel to any value other than 0, the device plugged into the backpanel's SCA connector inherits this AL_PA. In the event you don't successfully assign unique hard addresses (and therefore have duplicate selection IDs assigned to two or more devices), the FC-AL generates a message indicating this condition. If you set the AL_PA on the backpanel to a value of 0, the system issues a unique soft-assigned physical address automatically.

Loop initialization is the process used to verify or obtain an address. The loop initialization process is performed when power is applied to the drive, when a device is added or removed from the Fibre Channel loop, or when a device times out attempting to win arbitration.

- Set all option selections in the connector prior to applying power to the drive. If you change options after applying power to the drive, recycle the drive power to activate the new settings.
- It is not necessary to low-level format this drive. The drive is shipped from the factory low-level formatted in 512-byte logical blocks. You need to reformat the drive only if you want to select a different logical block size.

8.1 Drive ID/option selection

All drive options are made through the interface connector (J1). Table provides the pin descriptions for the 40-pin Fibre Channel single connector (J1).

8.2 LED connections

A connector, J6, is provided on the printed circuit board assembly (PCBA) to provide port bypass, drive active, and drive fault LED connections (see Figure 10). See Sections 9.5.7, 9.5.8, and 9.5.9 for descriptions of LED functions.

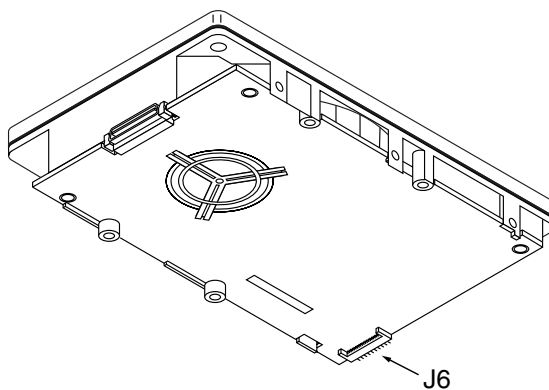
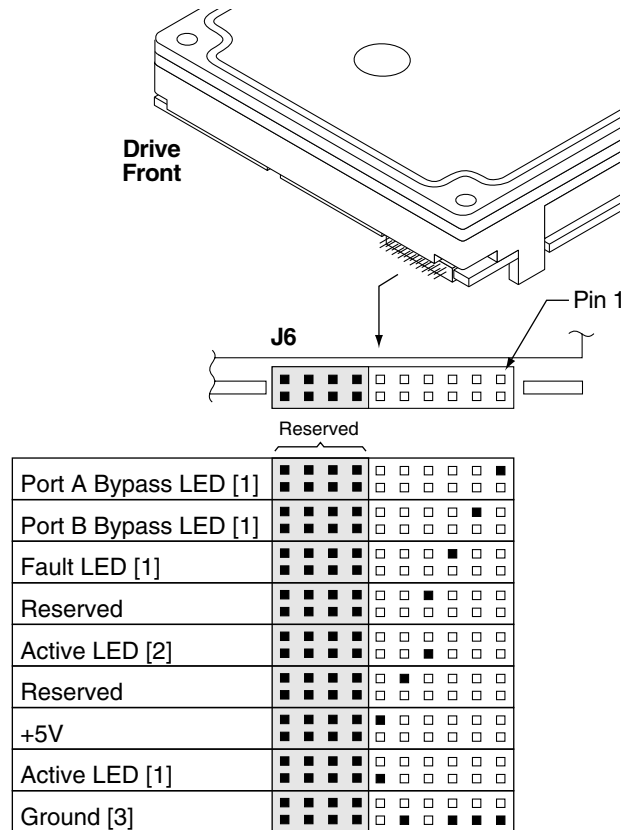

Figure 9. Physical interface



- [1] The drive has a 2.2K ohm resistor in series with this LED driver. Tie the minus side of an external high-efficiency LED (i.e., 2ma) to this pin. Connect the plus side of the LED to +5V.
- [2] An external current-limiting resistor is required when connecting an LED to this pin. The minus side of the resistor/LED combination is connected to this pin. Connect the plus side to +5V.
- [3] Jumper storage location (across pins 2 and 4).

Figure 10. LED indicator connector

8.2.1 J6 connector requirements

Recommended mating connector part number: Berg receptacle, 6-position, Berg part number 690-006.

8.3 Drive orientation

The drive may be mounted in any orientation. All drive performance characterizations, however, have been done with the drive in horizontal (discs level) and vertical (drive on its side) orientations, which are the two preferred mounting orientations.

8.4 Cooling

Cabinet cooling must be designed by the customer so that the ambient temperature immediately surrounding the drive will not exceed temperature conditions specified in Section 6.4.1, "Temperature." Specific consideration should be given to make sure adequate air circulation is present around the printed circuit board (PCB) to meet the requirements of Section 6.4.1, "Temperature."

8.4.1 Air flow

The rack, cabinet, or drawer environment for the drive must provide heat removal from the electronics and head and disc assembly (HDA). You should confirm that adequate heat removal is provided using the temperature measurement guidelines described in Section 6.4.1.

Forced air flow may be required to keep temperatures at or below the specified case temperatures of Table 3, in which case the drive should be oriented, or air flow directed, so that the least amount of air flow resistance is created while providing air flow to the electronics and HDA. Also, the shortest possible path between the air inlet and exit should be chosen to minimize the travel length of air heated by the drive and other heat sources within the rack, cabinet, or drawer environment.

If forced air is determined to be necessary, possible air-flow patterns are shown in Figure 11. The air-flow patterns are created by one or more fans, either forcing or drawing air as shown in the illustrations. Conduction, convection, or other forced air-flow patterns are acceptable as long as the temperature measurement guidelines of Section 6.4.1 are met.

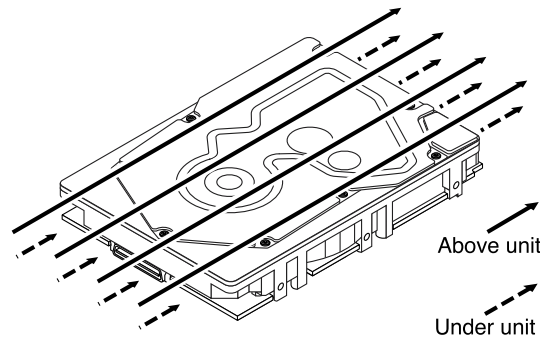

Note. Air flows in the direction shown (front to back) or in reverse direction (back to front)

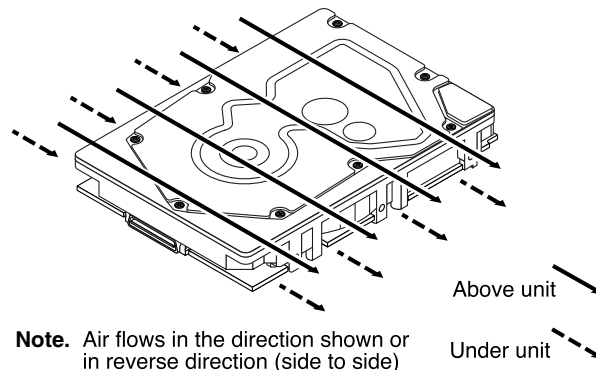

Note. Air flows in the direction shown or in reverse direction (side to side)

Figure 11. Air flow

8.5 Drive mounting

Mount the drive using the bottom or side mounting holes. If you mount the drive using the bottom holes, ensure that you do not physically distort the drive by attempting to mount it on a stiff, non-flat surface.

The allowable mounting surface stiffness is 80 lb/in (14.0 N/mm). The following equation and paragraph define the allowable mounting surface stiffness:

$$K \times X = F \leq 15\text{lb} = 67\text{N}$$

where K is the mounting surface stiffness (units in lb/in or N/mm) and X is the out-of-plane surface distortion (units in inches or millimeters). The out-of-plane distortion (X) is determined by defining a plane with three of the four mounting points fixed and evaluating the out-of-plane deflection of the fourth mounting point when a known force (F) is applied to the fourth point.

Note. Before mounting the drive in any kind of 3.5-inch to 5.25-inch adapter frame, verify with Seagate Technology that the drive can meet the shock and vibration specifications given herein while mounted in such an adapter frame. Adapter frames that are available may not have a mechanical structure capable of mounting the drive so that it can meet the shock and vibration specifications listed in this manual.

8.6 Grounding

Signal ground (PCBA) and HDA ground are connected together in the drive and cannot be separated by the user. The equipment in which the drive is mounted is connected directly to the HDA and PCBA with no electrically isolating shock mounts. If it is desired for the system chassis to not be connected to the HDA/PCBA ground, the systems integrator or user must provide a nonconductive (electrically isolating) method of mounting the drive in the host equipment.

Increased radiated emissions may result if you do not provide the maximum surface area ground connection between system ground and drive ground. This is the system designer's and integrator's responsibility.

9.0 Interface requirements

This section partially describes the interface requirements as implemented on Cheetah X15 FC drives. Additional information is provided in the *Fibre Channel Interface Manual* (part number 77767496).

9.1 FC-AL features

This section lists the Fibre Channel-specific features supported by Cheetah X15 FC drives.

9.1.1 Fibre Channel link service frames

Table 5 lists the link services supported by Cheetah X15 FC drives.

Table 5: Link services supported

Type of frame	Link service
Basic link service frames	Abort Sequence (ABTS)
Basic link service reply frames	Basic_Accept (BA_ACC) Basic_Reject (BA_RJT)
Extended link service frames	N_Port Login (PLOGI) Fabric Login (FLOGI) Logout (LOGO) Process Login (PRLI) Process Logout (PRLO) Read Link Status (RLS) Fabric Address Notification (FAN) Port Discovery (PDISC) Address Discovery (ADISC) Third-party Process Logout (TRPLO)
Extended link service reply frames	Accept (ACC) Link Service Reject (LS_RJT)
Fibre Channel Services	Register FC-4 Types (RFT_ID)

9.1.2 Fibre Channel task management functions

Table 6 lists the Fibre Channel SCSI Fibre Channel Protocol (FC SCSI FCP) task management functions supported.

Table 6: Fibre Channel SCSI FCP task management functions

Task name	Supported
Terminate task	No
Clear ACA	Yes
Target reset	Yes
Clear task set	Yes
Abort task set	Yes

9.1.3 Fibre Channel task management responses

Table 7 lists the FC SCSI FCP response codes returned for task management functions supported.

Table 7: FC SCSI FCP response codes

Function name	Response code
Function complete	00
Function not supported	04
Function reject	05

9.1.4 Fibre Channel port login

Table 8 identifies the required content of the N_Port Login (PLOGI) payload from an initiator.

Table 8: N_Port login (PLOGI) payload

Bytes																	
0-15	03	00	00	00	09	09	BB	BB	CF	XX	FS	FS	XX	XX	XX	XX	Common
16-31	XX	XX	XX	XX	PN	PN	PN	PN	PN	PN	PN	PN	NN	NN	NN	NN	
32-35	NN	NN	NN	NN													
36-47					XX	XX	XX	XX	XX	XX	XX	XX	XX	XX	XX	XX	Class 1
48-51	XX	XX	XX	XX													
52-63					XX	XX	XX	XX	XX	XX	XX	XX	XX	XX	XX	XX	Class 2
64-67	XX	XX	XX	XX													
68-79					SO	SO	IC	IC	XX	XX	FS	FS	XX	CS	XX	XX	Class 3
80-83	OS	OS	XX	XX													
84-95					XX	XX	XX	XX	XX	XX	XX	XX	XX	XX	XX	XX	Reserved
96-99	XX	XX	XX	XX													
100-111					XX	XX	XX	XX	XX	XX	XX	XX	XX	XX	XX	XX	Vendor
112-115	XX	XX	XX	XX													Version

X Indicates a four-bit (hex) field is not checked.

x Indicates a single bit is not checked.

BB BB-Credit. This field is not checked. The FC-AL drive uses BB-Credit of zero (0).

CF Common features. This binary field selects the common features requested by the initiator login.

MSB	Continuously increasing offset	Must = 1
	Random relative offset	Not checked. Port Login Accept will return a 0—not supported.
	Valid version level	x
	N_Port/F_Port	Must = 0, N_Port
	Alternate credit model	Must = 1
	Other bits reserved	xxx XX

FS Receive buffer field size. The FS field in the common and Class 3 parameters is checked for the range $256 < FS < 2,112$ and a multiple of four bytes. For multiple frame sequences, all frames but the last frame of the sequence must be this size. Only the receive buffer field size in the Class 3 parameters is used.

PN Port name (initiator's)—saved with the login parameters. If a change of the port name/AL_PA address association is detected during a Port DISCOVERY, and implicit logout occurs and the initiator returns a LS_RJT.

NN Node name. The node name is not checked or saved by the drive.

SO Service options Class 3 only.

MSB	Class valid	Must = 1
	Intermix	x
	Stacked connection req.	xx
	Sequential delivery	x
	Other bits reserved	xxx XX

IC Initiator control

MSB	XID reassign	xx
	Proc Assc	10 or 11 causes the login to be rejected. Other values are accepted.
	Other bits	XXX

CS Concurrent sequences Must be a value greater than 0.

OS Open sequences per exchange Must be a value greater than 0.

9.1.8 Fibre Channel fabric login

Table 12 lists the fabric login payload from the drive.

Table 12: Fabric Login (FLOGI) payload

Bytes																	
0-15	04	00	00	00	09	09	00	00	08	00	08	40	00	00	00	00	Common
16-31	00	00	02	F4	20	PP	00	20	37	UI	UI	UI	02	00	00	20	
32-35	37	UI	UI	UI													
36-47					00	00	00	00	00	00	00	00	00	00	00	00	Class 1
48-51	00	00	00	00													
52-63					00	00	00	00	00	00	00	00	00	00	00	00	Class 2
64-67	00	00	00	00													
68-79					80	00	00	00	00	00	08	40	00	00	00	00	Class 3
80-83	00	00	00	00													
84-95					00	00	00	00	00	00	00	00	00	00	00	00	Reserved
96-99	00	00	00	00													
100-111					00	00	00	00	00	00	00	00	00	00	00	00	Vendor -
112-115	00	00	00	00													Version

UI Unique identifier. This 24-bit field is uniquely assigned to the drive. This same UI appears in the Port Name and Node Name fields.

PP Port identifier field.

01 FLOGI originated on Port A.

02 FLOGI originated on Port B.

9.1.9 Fibre Channel fabric accept login

Table 12 lists the required content of the Fabric Login Accept (ACC) payload from the fabric.

Table 13: Fabric Login Accept (ACC) payload

Bytes																	
0-15	02	00	00	00	09	09	BB	BB	CF	XX	FS	FS	R_	A_	T0	V_	Common
16-31	E_	D_	T0	V_	PN	PN	PN	PN	PN	PN	PN	PN	NN	NN	NN	NN	
32-35	NN	NN	NN	NN													
36-47					XX	XX	XX	XX	XX	XX	XX	XX	XX	XX	XX	XX	Class 1
48-51	XX	XX	XX	XX													
52-63					XX	XX	XX	XX	XX	XX	XX	XX	XX	XX	XX	XX	Class 2
64-67	XX	XX	XX	XX													
68-79					SO	SO	xx	xx	XX	XX	FS	FS	XX	xx	XX	XX	Class 3
80-83	OS	OS	XX	XX													
84-95					XX	XX	XX	XX	XX	XX	XX	XX	XX	XX	XX	XX	Reserved
96-99	XX	XX	XX	XX													
100-111					XX	XX	XX	XX	XX	XX	XX	XX	XX	XX	XX	XX	Vendor -
112-115	XX	XX	XX	XX													Version

X Indicates a four-bit (hex) field is not checked.

x Indicates a single bit is not checked.

BB BB-Credit. This field is not checked. The FC-AL drive uses BB-Credit of zero (0).

CF Common features. This binary field selects the common features requested by the fabric login.

MSB	Continuously increasing offset	x
	Random relative offset	x
	Valid version level	x
	N_Port/F_Port	Must = 1, F_Port
	Alternate credit model	Must = 1
	Other bits reserved	xxx XX

FS Receive buffer field size. The FS field in the common and Class 3 parameters is checked for the range 256 < FS < 2,112 and a multiple of four bytes. The receive buffer field size in the Class 3 parameters is used. The drive uses the lower FS of Fabric Login Accept or N_Port Login when sending frames to an initiator.

PN Port Name. The fabric port name is saved with the login parameters. If a change of the port name is detected during a FAN, an implicit logout occurs and a LS_RJT is returned to the fabric.

NN Node Name. The drive does not check or save the node name.

SO Service Options—Class 3 only.

MSB	Class valid	Must = 1
	Intermix	x
	Stacked connection req.	xx
	Sequential delivery	Must = 1
	Other bits reserved	xxx XX

9.1.10 Fibre Channel Arbitrated Loop options

Table 14 lists the FC-AL options supported by Cheetah X15 FC drives.

Table 14: FC-AL options supported

Option	Supported
OPEN Half Duplex	Accepted from another device.
OPEN Full Duplex	Sent to open another device. Accepted from another device.
Private Loop	Yes
Public Loop	Yes
Old Port State	No
Loop Position	Yes
Loop Position Report	Yes

9.2 Dual port support

ST318451FC drives have two independent FC-AL ports. These ports may be connected on independent loops or on the same loop. Port A and Port B may be connected in any order or combination.

- If both ports are connected on independent loops and hard addressing is used, the drive interface address is selected through the interface connector, both ports will seek the same loop address. If no conflict, both ports will have the same loop address.
- If both ports are connected in the same loop and hard addressing is used, at least one port will attempt taking a soft address to prevent an address conflict.

Note. When a ST318451FC drive is connected in loops with previous Seagate FC drive products:

Barracuda 4LP FC (ST32171FC, ST34371FC, and ST34571FC)
 Barracuda 9FC (ST19171FC)
 Cheetah 4LP FC (ST34501FC)
 Cheetah 9FC (ST19101FC)

the connection of Port A and B for these products must follow the requirements in their product manuals.

Subject to buffer availability, the Cheetah X15 FC drives support:

- Concurrent port transfers—The drive supports receiving transfers on both ports at the same time when the ports are on independent loops.
- Full duplex—The drive supports sending FCP_Data, FCP_RSP, FCP_XFR_RDY and ELS transfers while receiving frames on both ports.

9.3 SCSI commands supported

Table 15 lists the SCSI commands supported by Cheetah X15 FC drives.

Table 15: Supported commands

Command code	Supported [4]	Command name
00h	Y	Test unit ready
01h	Y	Rezero unit
03h	Y	Request sense
	Y	Extended sense
	Y	Field pointer bytes
	Y	Actual retry count bytes
04h	Y	Format unit [1]
07h	Y	Reassign blocks
08h	Y	Read
0Ah	Y	Write
0Bh	Y	Seek
12h	Y	Inquiry
	Y	Vital product data page
	Y	Unit serial number page
	Y	Implemented operating def. page
	Y	Firmware numbers page
	Y	Date code page
	Y	Jumper settings page
15h	Y	Mode select (same pages as Mode Sense command shown below) [3]
16h	Y	Reserve
	N	3rd party reserved
	N	Extent reservation
17h	Y	Release
18h	N	Copy
1Ah	Y	Mode sense
	Y	Unit attention page (00h)
	Y	Error recovery page (01h)
	Y	Disconnect/reconnect control (page 02h)
	Y	Format page (03h)
	Y	Rigid disc drive geometry page (04h)
	Y	Verify error recovery page (07h)
	Y	Caching parameters page (08h)
	Y	Control mode page (0Ah)
	Y	Power control page (1Ah)
	Y	Information exceptions control page (1Ch)
1Bh	Y	Start unit/stop unit
1Ch	Y	Receive diagnostic results
	Y	Supported diagnostics pages
	Y	Translate page
	Y	Enclosure services page
1Dh	Y	Send diagnostics page

Table 15: Supported commands (*continued*)

Command code	Supported [4]	Command name
	Y	Supported diagnostics pages
	Y	Translate page
25h	Y	Read capacity
28h	Y	Read extended
	Y	Disable page out
	Y	Force unit access
	N	Relative address
2Ah	Y	Write extended
	Y	Disable page out
	Y	Force unit access
	N	Relative address
2Bh	Y	Seek extended
2Eh	Y	Write and verify
	Y	Disable page out
	Y	Byte check
	N	Relative address
2Fh	Y	Verify
	Y	Disable page out
	Y	Byte check
	N	Relative address
30h	N	Search data high
31h	N	Search data equal
32h	N	Search data low
33h	N	Set limits
34h	N	Prefetch
35h	Y	Synchronize cache
36h	N	Lock-unlock-cache
37h	Y	Read defect data
39h	N	Compare
3Ah	N	Copy and verify
3Bh	Y	Write buffer
	Y	Write combined header and data mode (0)
	Y	Write data mode (2)
	N	Download microcode mode (4)
	Y	Download microcode and save modes (5)
	N	Download microcode with offsets mode (6)
	Y	Download microcode with offsets and save mode (7)
	Y	Firmware download option [2]
3Ch	Y	Read buffer
	Y	Read combined header and data mode (0)
	Y	Read data mode (2)
	Y	Read descriptor mode (3)
3Eh	Y	Read long
3Fh	Y	Write long

Table 15: Supported commands (*continued*)

Command code	Supported [4]	Command name
40h	N	Change definition
41h	Y	Write same
	N	PBdata
	N	LBdata
42-4Bh	N	Not used
4Ch	Y	Log Select
4Dh	Y	Log Sense
4E-4Fh	N	Not used
50h	A	XD write
51h	A	XP write
52h	A	XD read
53-54h	N	Not used
55h	Y	Mode Select (10) [3]
56h	Y	Reserved (10)
	Y	3rd party reserve
	N	Extent reservation
57h	Y	Released (10)
58-59h	N	Not used
5Ah	Y	Mode Sense (10) [3]
5B-5Dh	N	Not used
5E	A	Persistent reserve in
5F	A	Persistent reserve out
60-7Fh	N	Not used
80h	A	XD write extended
81h	A	Rebuild
82h	A	Regenerate
83-8Fh	N	Not used
C0-DFh	N	Not used
EO-FFh	N	Not used

- [1] Cheetah X15 FC drives can format to any multiple of four bytes per logical block in the range 512 to 704 bytes.
- [2] **Warning.** Power loss during flash programming can result in firmware corruption. This usually makes the drive inoperable.
- [3] Reference Mode Sense command 1Ah for mode pages supported.
- [4] Y = Yes. Command is supported.
 N = No. Command is not supported.
 A = Support is available on special request.

9.3.1 Inquiry data

Table 16 lists the Inquiry command data that the drive should return to the initiator per the format given in the *Fibre Channel Interface Manual*.

Table 16: Cheetah X15 FC inquiry data

Bytes	Data (hex)																
0-15	00	00	**	32	8B	00	PP	0A	53	45	41	47	41	54	45	20	Vendor ID
16-31	[53	54	33	31	38	34	35	31	46	43	20]	20	20	20	20	20	Product ID
32-47	R#	R#	R#	R#	S#	S#	S#	S#	S#	S#	S#	S#	00	00	00	00	
48-63	00	00	00	00	00	00	00	00	00	00	00	00	00	00	00	00	
64-79	00	00	00	00	00	00	00	00	00	00	00	00	00	00	00	00	
80-95	00	00	00	00	00	00	00	00	00	00	00	00	00	00	00	00	
96-111	00	43	6F	70	79	72	69	67	68	74	20	28	63	29	20	32*	*Copyright
112-127	30*	30*	30*	20	53	65	61	67	61	74	65	20	41	6C	6C	20	notice
128-143	72	69	67	68	74	73	20	72	65	73	65	72	76	65	64	20	

* Copyright year (changes with actual year).

** 02 = SCSI-2 implemented with some SCSI-3 features (default).
03 = SCSI-3 implemented.

PP 50 = Inquiry data for an Inquiry command received on Port A.
70 = Inquiry data for an Inquiry command received on Port B.

R# Four ASCII digits representing the last four digits of the product firmware release number.

S# Eight ASCII digits representing the eight digits of the product serial number.

[] Bytes 16 through 26 reflect drive model.

9.3.2 Mode Sense data

The Mode Sense command provides a way for the drive to report its operating parameters to the initiator. The drive maintains four sets of mode parameters:

1. Default values

Default values are hard-coded in the drive firmware stored in flash E-PROM (nonvolatile memory) on the drive's PCB. These default values can be changed only by downloading a complete set of new firmware into the flash E-PROM. An initiator can request and receive from the drive a list of default values and use those in a Mode Select command to set up new current and saved values, where the values are changeable.

2. Saved values

Saved values are stored on the drive's media using a Mode Select command. Only parameter values that are allowed to be changed can be changed by this method. Parameters in the saved values list that are not changeable by the Mode Select command get their values from default values storage.

When power is applied to the drive, it takes saved values from the media and stores them as current values in volatile memory. It is not possible to change the current values (or the saved values) with a Mode Select command before the drive achieves operating speed and is "ready." An attempt to do so results in a "Check Condition" status.

On drives requiring unique saved values, the required unique saved values are stored into the saved values storage location on the media prior to shipping the drive. Some drives may have unique firmware with unique default values also.

On standard OEM drives, the saved values are taken from the default values list and stored into the saved values storage location on the media prior to shipping.

3. Current values

Current values are volatile values being used by the drive to control its operation. A Mode Select command can be used to change the values identified as changeable values. Originally, current values are installed from saved or default values after a power on reset, hard reset, or Bus Device Reset message.

4. Changeable values

Changeable values form a bit mask, stored in nonvolatile memory, that dictates which of the current values and saved values can be changed by a Mode Select command. A one (1) indicates the value can be changed. A zero (0) indicates the value is not changeable. For example, in Table 17, refer to Mode page 81, in the row entitled "CHG." These are hex numbers representing the changeable values for Mode page 81. Note in columns 5 and 6 (bytes 04 and 05), there is 00h which indicates that in bytes 04 and 05 none of the bits are changeable. Note also that bytes 06, 07, 09, 10, and 11 are not changeable, because those fields are all zeros. In byte 02, hex value FF equates to the binary pattern 11111111. If there is a zero in any bit position in the field, it means that bit is not changeable. Since all of the bits in byte 02 are ones, all of these bits are changeable.

The changeable values list can only be changed by downloading new firmware into the flash E-PROM.

Note. Because there are often several different versions of drive control firmware in the total population of drives in the field, the Mode Sense values given in the following tables may not exactly match those of some drives.

The following tables list the values of the data bytes returned by the drive in response to the Mode Sense command pages for SCSI implementation (see the *Fibre Channel Interface Manual*).

Definitions:

DEF = Default value. Standard OEM drives are shipped configured this way.

CHG = Changeable bits; indicates if default value is changeable.

9.4 Miscellaneous operating features and conditions

Table 18 lists various features and conditions. A “Y” in the support column indicates the feature or condition is supported. An “N” in the support column indicates the feature or condition is not supported.

Table 18: Miscellaneous features

Supported	Feature or condition
Y	FC-AL selective reset
Y	Automatic contingent allegiance
N	Asynchronous event notification
N	Synchronized (locked) spindle operation
Y	Segmented caching
N	Zero latency read
Y	Queue tagging (up to 128 queue tags supported)
Y	Deferred error handling
Y	Parameter rounding (controlled by Round bit in Mode Select page 0)
Y	Reporting actual retry count in Extended Sense bytes 15, 16, and 17
N	Adaptive caching
Y	SMP = 1 in Mode Select command needed to save RPL and rotational offset bytes

Table 19: Miscellaneous status

Supported	Status
Y	Good
Y	Check condition
Y	Condition met/good
Y	Busy
Y	Intermediate/good
Y	Intermediate/condition met/good
Y	Reservation conflict
Y	Task set full
Y	ACA active
Y	ACA active, faulted initiator

9.5 FC-AL physical interface

Figure 12 shows the location of the J1 Fibre Channel single connection attachment (FC-SCA) and the J6 connector. Figure 14 provides the dimensions of the FC-SCA. Figure 15 provides the dimensions of the J6 connector.

Details of the physical, electrical, and logical characteristics are provided within this section. The operational aspects of Seagate's Fibre Channel drives are provided in the *Fibre Channel Interface Manual*.

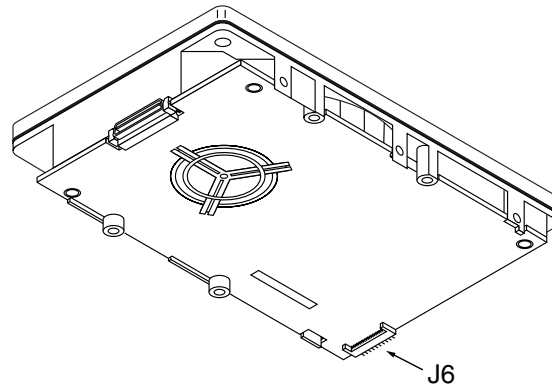

Figure 12. Physical interface

9.5.1 Physical characteristics

This section defines physical interface connector.

9.5.1.1 Physical description

Fibre Channel drives may be connected in a loop together or with other compatible FC-AL devices. A maximum of 127 devices may have addresses; however, one of the addresses is reserved for a fabric port switch device. This means 126 addresses are available for FC-AL devices. More FC-AL compatible devices may physically reside on the loop, but they will not be functional because they would not be able to obtain valid addresses.

Port bypass circuits (PBCs) allow devices to be inserted into unpopulated locations or removed from the loop with loop operation recovery after a brief interruption. These PBCs are located external to the FC-AL device. Figure 13 shows the relationship between the PBC and FC-AL device.

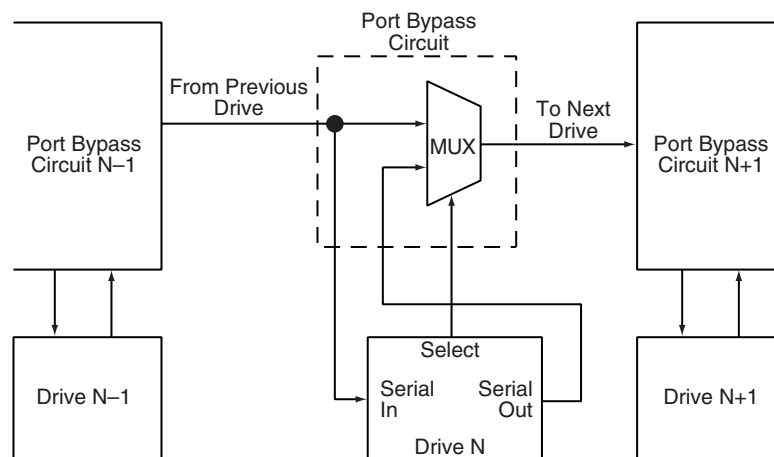

Figure 13. Port bypass circuit physical interconnect

9.5.2 Connector requirements

Recommended mating SCA part number:

Part description	Positions	Part number	Features
AMP Vertical (SCA sequence)	40	787317-1	With polarization
Berg	40	71781	With polarization
Methode	40	512-220-91-101N	With polarization
Molex	40	717431040	With polarization

The FC-AL SCA device connector is illustrated in Figure 14. The J6 connector is illustrated in Figure 15.

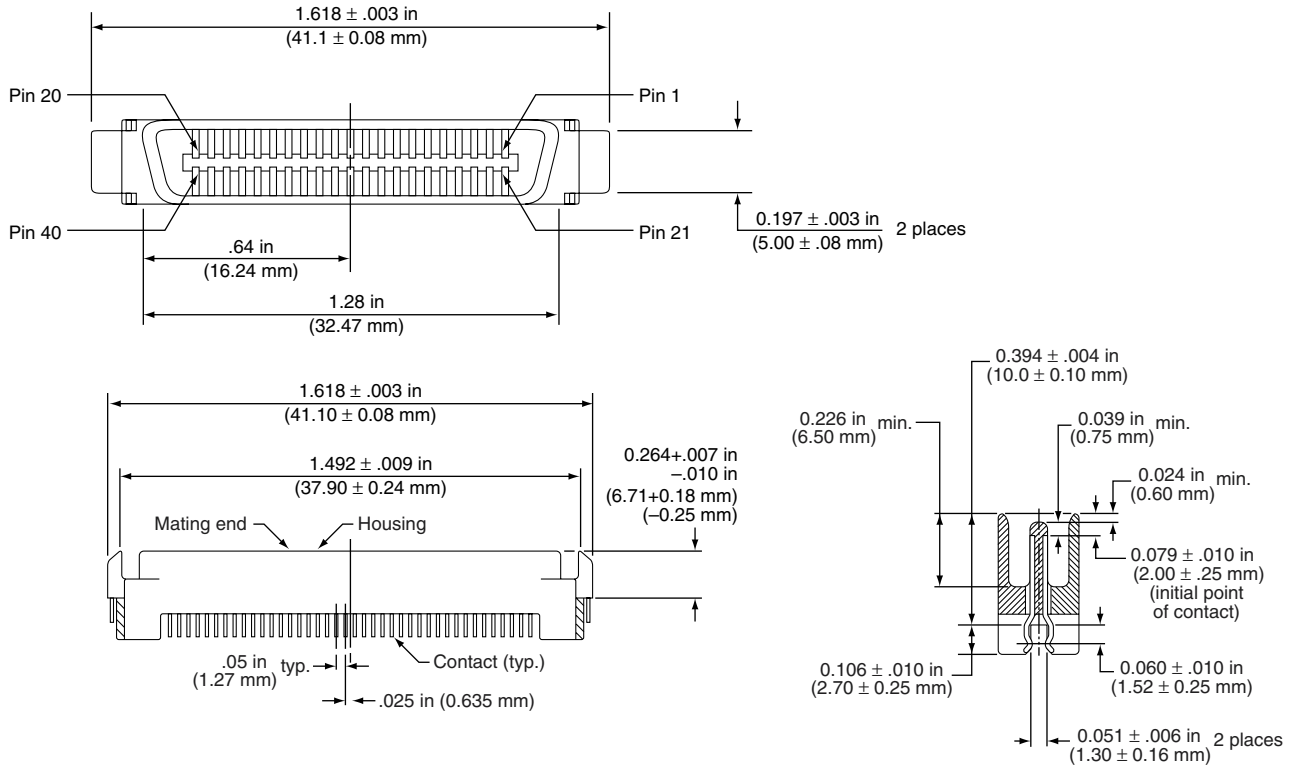

Figure 14. FC-AL SCA device connector dimensions

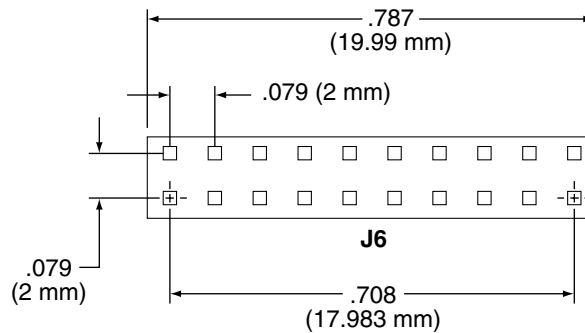

Figure 15. J6 connector dimensions

9.5.3 Electrical description

Fibre Channel drives use the FC-SCA connector for:

- DC power
- FC-AL interface
- Drive select (device identification)
- Option selection
- Enclosure Services interface

This 40-pin connector is designed to plug directly into a backpanel. External cables are not required.

9.5.4 Pin descriptions

This section provides a pin-out of the FC-SCA and a description of the functions provided by the pins.

Table 20: FC-SCA pin descriptions

Pin	Signal name	Signal type	Pin	Signal name	Signal type
1*	-EN bypass port A	Low Voltage TTL output	21	12 Volts charge	
2*	12 Volts		22	Ground	
3*	12 Volts		23	Ground	
4*	12 Volts		24*	+Port A_in	Diff. PECL input pair
5*	-Parallel ESI		25*	-Port A_in	
6*	Ground ^[1]		26	Ground	
7*	Active LED out	Open collector out	27*	+Port B_in	Diff. PECL input pair
8*	Reserved		28*	-Port B_in	
9*	Start_1 ^[2]	TTL input	29	Ground	
10*	Start_2 ^[2]	TTL input	30*	+Port A_out	Diff PECL output pair
11*	-EN bypass port B	Low Voltage TTL output	31*	-Port A_out	
12*	SEL_6	TTL input/output	32	Ground	
13*	SEL_5	TTL input/output	33*	+Port B_out	Diff PECL output pair
14*	SEL_4	TTL input	34*	-Port B_out	
15*	SEL_3	TTL input/output	35	Ground	
16*	Fault LED out	Open collector out	36	SEL_2	TTL input/output
17*	DEV_CTRL_CODE_2 ^[2]	TTL input	37	SEL_1	TTL input/output
18*	DEV_CTRL_CODE_1 ^[2]	TTL input	38	SEL_0	TTL input/output
19*	5 Volts		39	DEV_CTRL_CODE_0 ^[2]	TTL input
20*	5 Volts		40	5 Volts charge	

*Short pins in mating backpanel connector.

- [1] This pin may be connected to external logic to detect the presence of the drive. The drive connects this pin to the common ground.
- [2] Pins 9, 10, 17, 18, and 39 are option select pins and are tied high by the drive circuitry. The preferred electrical connection at the backplane is either open or grounded (open for the '1' setting, grounded for the '0' setting). Alternatively, these pins may be driven by a 3.3V logic device, pulled up to 3.3V through a pull-up resistor (recommended size of 10K ohm), or grounded through some other means.

9.5.5 FC-AL transmitters and receivers

A typical FC-AL differential copper transmitter and receiver pair is shown in Figure 16. The receiver is required to provide the AC coupling to eliminate ground shift noise.

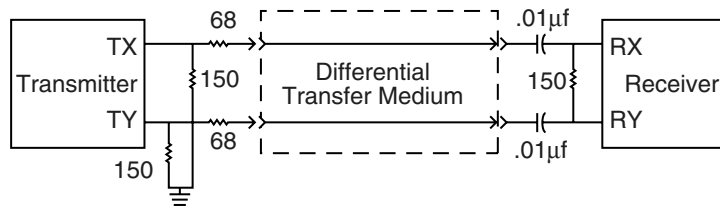

Figure 16. FC-AL transmitters and receivers

9.5.6 Power

Power is supplied through the FC-SCA with support for +5 volts and +12 volts. All of the voltage pins in the drive connector are the same length.

Four 12 volt pins provide +12 volt power to the drive. The current return for the +12 volt power supply is through the common ground pins. The supply current and return current must be distributed as evenly as possible among the pins. The maximum current typically occurs while the drive motor is starting.

Three 5 volt pins provide logic power to the drive. The current return for the +5 volt power supply is through the common ground pins. Distribute supply and return current as evenly as possible among the voltage and ground pins.

The mating connector pins use shorter contacts to achieve power surge reductions and to aid in “hot plugging” the drives. There are longer voltage contacts in the connector to enable the drive filter capacitors to charge. Current to the drive through the long charge pins is limited by the system in which the drive operates. Three of the +12 volt pins are shorter to allow capacitive pre-charging through the longer +12 volt charge pin. Two of the +5 volt pins are shorter to allow capacitive precharging through the longer +5 volt charge pin.

9.5.7 Fault LED Out

The Fault LED Out signal is driven by the drive when:

- the drive detects failure of both ports
- the drive detects an internal failure
- the drive receives the appropriate fault LED command from the host

The Fault LED Out signal is designed to pull down the cathode of an LED. The anode is attached to the proper +5 volt supply through an appropriate current-limiting resistor. The LED and the current-limiting resistor are external to the drive.

9.5.8 Active LED Out

The Active LED Out signal is driven by the drive as indicated in Table 21.

Table 21: Active LED Out conditions

Normal command activity	LED status
Spun down and no activity	Slow blink (20% on and 80% off a 2 sec cycle)
Spun down and activity (command executing)	On
Spun up and no activity	On
Spun up and activity (command executing)	Off
Spinning up or down	Blinks steadily (50% on and 50% off)
Format in progress, each cylinder change	Toggles on/off

The Active LED Out signal is designed to pull down the cathode of an LED. The anode is attached to the proper +5 volt supply through an appropriate current limiting resistor. The LED and the current limiting resistor are external to the drive.

9.5.9 Enable port bypass signals

The – Enable Bypass Port A (– EN BYP Port A) and – Enable Bypass Port B (– EN BYP Port B) signals control the port bypass circuits (PBC) located external to the disc drive. The PBC allows a loop to remain functional in the event of a drive failure or removal. When these signals are active, low, the PBC bypasses the drive on the associated port. When an Enable Bypass signal is active, the corresponding Port Bypass LED signal in connector J1 is driven low by the disc drive. A pull down resistor, 1K, located with the PBC should be used to insure the bypass is enabled if the disc drive is not installed.

The Enable Bypass signal is active under failing conditions within the drive, on detection of the Loop Port Bypass primitive sequence, or on removal of the drive. In the bypass state the drive continues to receive on the inbound fibre. Enable Bypass may be deactivated by detection of a Loop Port Enable primitive sequence if the drive has completed self-test and a hardware failure is not present.

Failure modes detected by the disc drive that will enable bypass include:

- Transmitter/receiver wrap test failure
- Loss of receive clock
- Loss of transmission clock
- Drive interface hardware error

9.5.10 Motor start controls

The drive's motor is started according to the Start_1 and Start_2 signals described in Table 22. The state of these signals can be wired into the backplane socket or driven by logic on the backplane.

Table 22: Motor start control signals

Case	Start_2	Start_1	Motor spin function
1	Low	Low	Motor spins up at DC power on.
2	High	Low	Motor spins up only when SCSI Start command is received.
3	Low	High	Motor spins up after a delay of 12 seconds times the modulo 8 value of the numeric SEL ID of the drive from DC power on.
4	High	High	The drive will not spin up.

9.5.11 SEL_6 through SEL_0 ID lines

The SEL_6 through SEL_0 ID lines determine drive address, and, optionally, for an Enclosure Services Interface. When the Parallel ESI line is high, the enclosure backpanel must provide address information on the SEL line. Refer to table 24 for a mapping of SEL to FC-AL physical addresses (AL_PA). You can think of the SEL lines as the equivalent of a backpanel logic plug. The drives does not provide pull up resistors on these lines. The backpanel is required to provide high and low inputs to the SEL_ID lines per the specifications in table 25 on page 57.

Note. Table 24 gives AL_PA values for each SEL value. The first entry in the table is SEL_ID 00. The last entry is SEL_ID 7D. SEL_ID 7E is AL_PA 00 which is not valid for an NL_Port, so is not included in the table. Also, SEL_ID 7Fh does map to a valid AL_PA; however, this value signals the drive that physical addresses are not being assigned using the SEL lines and that a “soft” address will be determined by FC-AL loop initialization.

When the Parallel ESI line is low, the enclosure backpanel logic switches to ESI mode if supported. There are two modes of ESI, seven bits of enclosure status and a bidirectional mode. ESI support and the mode are determined by the drive using a discovery process. Refer to the *Fibre Channel Interface Manual* for a description of ESI operation.

9.5.11.1 Parallel Enclosure Services Interface (ESI)

The parallel ESI line is an output from the drive. This line provides the enclosure with an indication of the present function of the SEL lines. A high level, the default state, indicates the drive requires address information on the SEL lines. A low level indicates the drive is attempting an ESI transfer. The enclosure may not support ESI on any or all drive locations. It may only support the address function. Support of ESI is discovered by the drive. Refer to the *Fibre Channel Interface Manual* for a description of ESI operations.

9.5.12 Device control codes

The drive inputs a Device Control Code on the DEV_CTRL_CODE lines at power up to determine the link rate on the Fibre Channel ports. Both ports run at the same rate. If the backpanel does not connect to these lines, the drive has 10K ohm pull up resistors that default the device control code to 7 (1.0625 GHz). Table 23 lists the supported codes.

Table 23: Device control code values

2 (pin 17)	1 (pin 18)	0 (pin 39)	Definition
0	0	0	Reserved for power failure warning.
0	0	1	Reserved for auto negotiation of link rate.
0	1	0	Reserved.
0	1	1	Reserved.
1	0	0	Reserved.
1	0	1	Reserved.
1	1	0	2.125 GHz operation on both ports.
1	1	1	1.0625 GHz operation on both ports.

Table 24: Arbitrated loop physical address (AL_PA) values

AL_PA (hex)	SEL ID (hex)	Setting (dec)
EF	00	00
E8	01	01
E4	02	02
E2	03	03
E1	04	04
E0	05	05
DC	06	06
DA	07	07
D9	08	08
D6	09	09
D5	0A	10
D4	0B	11
D3	0C	12
D2	0D	13
D1	0E	14
CE	0F	15
CD	10	16
CC	11	17
CB	12	18
CA	13	19
C9	14	20
C7	15	21
C6	16	22
C5	17	23
C3	18	24
BC	19	25
BA	1A	26
B9	1B	27
B6	1C	28
B5	1D	29
B4	1E	30
B3	1F	31
B2	20	32
B1	21	33
AE	22	34
AD	23	35
AC	24	36
AB	25	37
AA	26	38
A9	27	39
A7	28	40
A6	29	41
A5	2A	42

AL_PA (hex)	SEL ID (hex)	Setting (dec)
A3	2B	43
9F	2C	44
9E	2D	45
9D	2E	46
9B	2F	47
98	30	48
97	31	49
90	32	50
8F	33	51
88	34	52
84	35	53
82	36	54
81	37	55
80	38	56
7C	39	57
7A	3A	58
79	3B	59
76	3C	60
75	3D	61
74	3E	62
73	3F	63
72	40	64
71	41	65
6E	42	66
6D	43	67
6C	44	68
6B	45	69
6A	46	70
69	47	71
67	48	72
66	49	73
65	4A	74
63	4B	75
5C	4C	76
5A	4D	77
59	4E	78
56	4F	79
55	50	80
54	51	81
53	52	82
52	53	83
51	54	84
4E	55	85

AL_PA (hex)	SEL ID (hex)	Setting (dec)
4D	56	86
4C	57	87
4B	58	88
4A	59	89
49	5A	90
47	5B	91
46	5C	92
45	5D	93
43	5E	94
3c	5F	95
3A	60	96
39	61	97
36	62	98
35	63	99
34	64	100
33	65	101
32	66	102
31	67	103
2E	68	104
2D	69	105
2C	6A	106
2B	6B	107
2A	6C	108
29	6D	109
27	6E	110
26	6F	111
25	70	112
23	71	113
1F	72	114
1E	73	115
1D	74	116
1B	75	117
18	76	118
17	77	119
10	78	120
0F	79	121
08	7A	122
04	7B	123
02	7C	124
01	7D	125

9.6 Signal characteristics

This section describes the electrical signal characteristics of the drive's input and output signals. See Table 20 on page 52 for signal type and signal name information.

9.6.1 TTL input characteristics

Table 25 provides the TTL characteristics.

Table 25: TTL characteristics

State	Voltage	Current
Input high	$1.9 < V_{IH} < 5.5V$	$I_{IH} = \pm 500nA$ max.
Input low	$-0.5V < V_{IL} < 0.9V$	$I_{OL} = \pm 500nA$ max.
Output high (-EN Bypass A, B)	$2.4 < V_{OH} < 5.25V$	$I_{OH} < -3mA$
Output low (-EN Bypass A, B)	$V_{OL} < 0.5V$	$I_{OL} < 3mA$
Output high (-Parallel ESI)	$2.4 < V_{OH} < 0.9 V_{CC}$ $V_{OH} > 0.9V_{CC}$	$I_{OH} < -2.4mA$ $I_{OH} < -500\mu A$
Output low (-Parallel ESI)	$0 < V_{OL} < .45V$	$I_{OL} < 2.4mA$
Output high (all other outputs)	$2.4 < V_{OH} < 0.9 V_{CC}$ $V_{OH} > 0.9V_{CC}$	$I_{OH} < -1.6mA$ $I_{OH} < -500\mu A$
Output low (all other outputs)	$0 < V_{OL} < .45V$	$I_{OL} < 1.6mA$

9.6.2 LED driver signals

Fault and Active LED signals are located in the FC-SCA connector (J1) and through the indicator connector (J6). See Table 26 for the output characteristics of the LED drive signals.

Table 26: LED drive signal

State	Current drive available	Output voltage
LED off, high	$0 < I_{OH} < 100\mu A$	
LED on, low	$I_{OL} < -30 mA$	$0 < V_{OL} < 0.8V$

9.6.3 Differential PECL output

The serial PECL output signal voltage characteristics are provided in Table 27. The outputs are not AC coupled in order to deliver maximum signal without rise and fall time degradation. You must AC couple the receiver to isolate potentially different DC characteristics of the outputs and the receiver.

Table 27: Differential PECL output characteristics

Description	Parameter	Notes
Serial output voltage swing	$300 < V_{out} < 650 mV$	Centered at 1.32V

Figure 17 provides the data output valid eye diagram relative to the bit cell time.

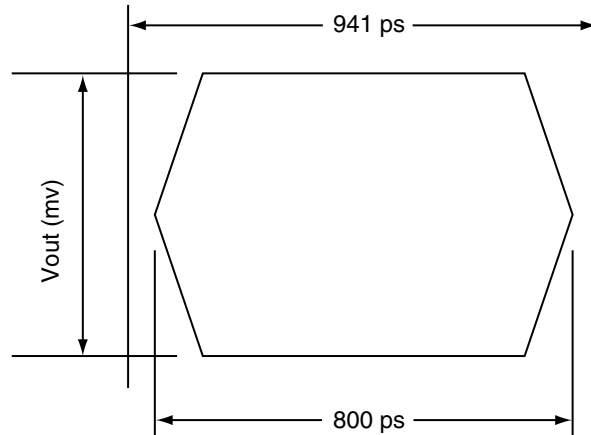

Figure 17. Transmit eye diagram

9.6.4 Differential PECL input

The serial PECL input signal voltage characteristics are provided in Table 28.

Table 28: Differential PECL input characteristics

Description	Parameter	Notes
Serial input voltage swing	$200 < V_{in} < 1.300 \text{ mV}$	AC coupled

Figure 18 provides the data valid eye diagram for typical and minimum requirements to recover data at the specified interface error rate. The inputs are AC coupled on the drive.

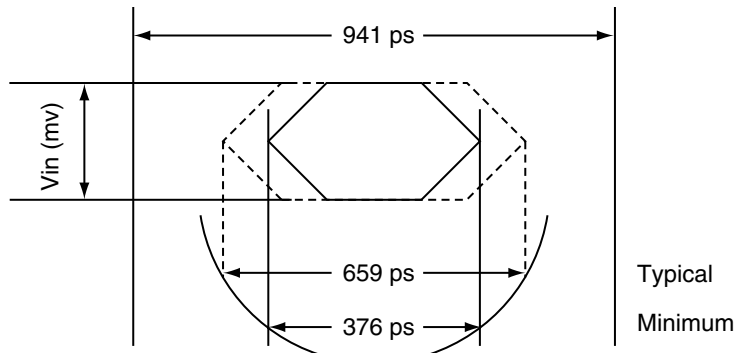

Figure 18. Receive eye diagram

10.0 Seagate Technology support services

Online Services

Internet

www.seagate.com for information about Seagate products and services. Worldwide support is available 24 hours daily by e-mail for your disc or tape questions.

Presales Support:

Disc: www.seagate.com/support/email/email_presales.html or DiscPresales@Seagate.com.

Tape: www.seagate.com/support/email/email_tape_presales.html or Tape_Sales_Support@Seagate.com.

Technical Support:

Disc: www.seagate.com/support/email/email_disc_support.html or DiscSupport@Seagate.com.

Tape: www.seagate.com/support/email/email_tape_support.html or TapeSupport@Seagate.com.

Reseller Marketplace

Reseller Marketplace is the storage industry's first collaborative, e-commerce marketplace offering resellers the fastest, most efficient online purchasing process for Seagate storage solutions. The Reseller Marketplace at marketplace.seagate.com, an exclusive service for US resellers participating in the Seagate Partner Program (SPP), is designed to streamline the purchasing process of Seagate solutions and provide unprecedented value to Seagate's resellers through real-time pricing and availability, fast and easy comparison shopping, and seamless integration with key distributors for a one-stop shopping experience.

For support, questions and comments: reseller.seagate.com/benefits/T1.html or 1-877-271-3285 (toll-free) 9 A.M. to 7 P.M. (eastern time) Monday through Friday.

Tape Purchases

US customers can purchase Seagate data cartridges, tape supplies, accessories, and select Seagate tape drive products 24 hours daily at buytape.seagate.com.

Automated Services

SeaFONE® (1-800-SEAGATE) is Seagate's toll-free number (1-800-732-4283) to access our automated self-help services. Using a touch-tone phone, you can find answers to service phone numbers, commonly asked questions, troubleshooting tips and specifications for disc drives and tape drives 24 hours daily. International callers can reach this service by dialing +1-405-936-1234.

SeaFAX® (1-800-SEAGATE) is Seagate's automated FAX delivery system. Using a touch-tone phone, you can obtain technical support information by return FAX 24 hours daily.

Presales Support

Presales Support

Our Presales Support staff can help you determine which Seagate products are best suited for your specific application or computer system.

Technical Support

If you need help installing your drive, consult your dealer. Dealers are familiar with their unique system configurations and can help you with system conflicts and other technical issues. If you need additional help, you can talk to a Seagate technical support specialist. Before calling, note your system configuration and drive model number (ST####).

SeaTDD™ (+1-405-936-1687) is a telecommunications device for the deaf (TDD). You can send questions or comments 24 hours daily and exchange messages with a technical support specialist from 8:00 A.M. to 11:45 A.M. and 1:00 P.M. to 6:00 P.M. (central time) Monday through Friday.

Customer Service (CSO)

Warranty Service

Seagate offers worldwide customer support for Seagate drives. Seagate direct OEM, Distribution and System Integrator customers should contact their Seagate service center representative for warranty information. Other customers should contact their place of purchase.

Authorized Service Centers

If you live outside the US, you can contact an Authorized Service Center for service.

USA/Canada/Latin America Support Services

Presales Support

Call Center	Toll-free	Direct dial	FAX
<i>Disc:</i>	1-877-271-3285	+405-936-1210	+1-405-936-1683
<i>Tape:</i>	1-800-626-6637	+1-714-641-2500	+1-714-641-2410

Technical Support (SeaFONE)

1-800-SEAGATE or +1-405-936-1234 (for specific product phone number)
 FAX: *Disc:* +1-405-936-1685; *Tape and Server Appliance:* +1-405-936-1683

SeaFAX	1-800-SEAGATE
SeaTDD	+1-405-936-1687

Warranty Service

Call Center	Toll-free	Direct dial	FAX / Internet
USA	1-800-468-3472	+1-405-936-1456	+1-405-936-1462
Mexico and Latin America	—	+1-405-936-1456	+1-405-936-1464
Canada			
<i>Memofix</i> ¹	1-800-636-6349	+1-905-660-4936	+1-905-660-4951 www.memofix.com
<i>Adtech</i> *	1-800-624-9857	+1-905-812-8099	+1-905-812-7807 www.adtech1.com
Brazil			
<i>MA Centro de Serviços</i> *	—	+55-21-509-7267	+55-21-507-6672 e-mail: sgt_cso@gbl.com.br

European Support Services

For European customer support, dial the toll-free number for your specific country for presales support, technical support and warranty service.

If your country is not listed here, dial our European call center at +31-20-316-7222 from 8:30 A.M. to 5:00 P.M. (European central time) Monday through Friday. The European call center is located in Amsterdam, The Netherlands.

Call Center

Austria	0 800-20 12 90
Belgium	0 800-74 876
Denmark	80 88 12 66
France	0 800-90 90 52
Germany	0 800-182 6831
Ireland	1 800-55 21 22
Italy	800-790695
Netherlands	0 800-732 4283
Norway	800-113 91
Poland	00 800-311 12 38

1. Authorized Service Centers

Spain	900-98 31 24
Sweden	0 207 90 073
Switzerland	0 800-83 84 11
Turkey	00 800-31 92 91 40
United Kingdom	0 800-783 5177

Fax Services—All European Countries

Presales/Technical Support/Warranty Service 31-20-653-3513

Africa/Middle East Support Services

For presales, technical support, warranty service and FAX services in Africa and the Middle East, dial our European call center at +31-20-316-7222 from 8:30 A.M. to 5:00 P.M. (European central time) Monday through Friday, or send a FAX to +31-20-653-3513. The European call center is located in Amsterdam, The Netherlands.

Asia/Pacific Support Services

For Asia/Pacific presales and technical support, dial the toll-free number for your specific country. The Asia/Pacific toll-free numbers are available from 6:00 A.M. to 10:45 A.M. and 12:00 P.M. to 6:00 P.M. (Australian eastern time) Monday through Friday. If your country is not listed here, direct dial one of our technical support locations.

Call Center	Toll-free	Direct dial	FAX
Australia	1800-14-7201	—	—
China	—	—	+86-10-6871-4316
Hong Kong	800-90-0474	—	+852-2368 7173
Indonesia	001-803-1-003-2165	—	—
Japan	—	—	+81-3-5462-2979
Malaysia	1-800-80-2335	—	—
New Zealand	0800-443988	—	—
Singapore	800-1101-150	+65-488-7584	+65-488-7528
Taiwan	—	+886-2-2514-2237	+886-2-2715-2923
Thailand	001-800-11-0032165	—	—

Warranty Service

Call Center	Toll-free	Direct dial	FAX
Asia/Pacific	—	+65-485-3595	+65-488-7503
Australia	1800-12-9277	—	—
Japan	—	+81-3-5462-2904	+81-3-5462-2979

Index

Numerics

- 12 volt
 - pins 53
- 3rd party reserve command 45
- 5 volt pins 53

A

- Abort Sequence (ABTS) 37
- abort task set function 37
- AC coupling 53
- AC power requirements 21
- ACA active status 49
- ACA active, faulted initiator status 49
- Accept (ACC) 37
- acoustics 28
- active LED Out signal 53
- Actual retry count bytes command 43
- actuator 7
 - assembly design 5
- adaptive caching 49
- Address Discovery (ADISC) 37
- addresses 50
- air cleanliness 28
- air flow 24, 35
 - illustrated 35
- air inlet 35
- Alternate credit model 38, 41
- altitude 26
- ambient 25
- ambient temperature 24, 34
- ANSI documents
 - fibre channel 4
 - SCSI 4
- arbitrated loop physical address (AL_PA) 33
- arbitration 33
- asynchronous event notification 49
- audible noise 3
- auto write and read reallocation
 - programmable 6
- automatic contingent allegiance 49
- average idle current 21
- average rotational latency 9

B

- backpanel 52
- backplane 54
- basic link service frames 37
- Basic_Accept (BA_ACC) 37
- Basic_Reject (BA_RJT) 37
- BB 38, 41
- BB-Credit 38, 41
- buffer
 - data 6

- space 11
- busy status 49
- bypass circuit 15
- Byte check command 44
- bytes per surface 9
- bytes per track 9

C

- cache operation 11
- cache segments 11
- Caching parameters page (08h) command 43
- caching write data 11
- Canadian Department of Communications 3
- capacity
 - formatted 7
 - unformatted 7, 9
- case temperature 24
- CF 38, 41
- Change definition command 45
- character sync 15
- charge pins 53
- check condition status 49
- Class 3 parameters 38, 41
- class B limit 3
- Class valid 38, 41
- clear ACA function 37
- clear task set function 37
- commands supported 43
- Common features 38, 41
- Compare command 44
- Concurrent sequences 38
- condensation 26
- condition met/good status 49
- connector
 - illustrated 51
 - requirements 51
- continuous vibration 28
- Continuously increasing offset 38, 41
- Control mode page (0Ah) command 43
- cooling 34
- Copy and verify command 44
- Copy command 43
- CRC 15
 - error 13
- CS 38
- Current profiles 22
- customer service 19

D

- data block size
 - modifying the 7
- data buffer to/from disc media 10
- data heads
 - read/write 9
- data rate
 - internal 9
- data transfer rate 10

- data valid eye 58
- Date code page command 43
- DC power 52
 - requirements 21
- defect and error management 31
- deferred error handling 49
- description 5
- device selection IDs 33
- devices 33
- differential PECL input 58
- dimensions 29
- Disable page out command 44
- disc rotation speed 9
- Disconnect/reconnect control (page 02h) command 43
- Download microcode and save modes (5) 44
- Download microcode mode (4) 44
- Download microcode with offsets and save mode (7) 44
- Download microcode with offsets mode (6) 44
- drive 28
- drive active LED connection 33
- drive characteristics 9
- drive fault LED connection 33
- drive ID 33
- drive ID/option select headers 33
- drive mounting 29, 35
- drive orientation 34
- drive select 52
- driver signals 57
- drivers and receivers 6
- dual port support 42

E

- electrical
 - description of connector 52
 - signal characteristics 57
 - specifications 21
- electromagnetic compatibility 3
- electromagnetic interference (EMI) 13
- electromagnetic susceptibility 28
- EMI 13
- EMI requirements 3
- enable bypass
 - port A 54
 - port B 54
 - signal 54
 - state 15
- Enclosure Services interface 52
- Enclosure services page command 43
- environment 35
- environmental
 - interference 13
 - limits 24
 - requirements 13
- environmental control 28
- error

- detection mechanisms, FC 15
 - management 31
 - rates 13
- error correction code
 - 96-bit Reed-Solomon 6
- Error recovery page (01h) command 43
- extended link service
 - frames 37
 - reply frames 37
- Extended sense command 43
- Extent reservation command 45

F

- fabric 41
- Fabric Address Notification (FAN) 37
- Fabric Login (FLOGI) 37
- FAN 41
- fault LED out signal 53
- FC-AL
 - document 4
 - interface 33, 52
 - options supported 42
 - physical interface 50
 - SCA device connector, illustrated 51
 - selective reset 49
- FCC rules and regulations 3
- FCP
 - for SCSI, document 4
 - response codes 37
 - task management functions 37
- FC-PH document 4
- features 6
 - interface 37
- Fibre Channel documents 4
- Fibre Channel Interface Manual 1, 3, 4
- Fibre Channel Services 37
- Field pointer bytes command 43
- firmware 6
 - corruption 45
- Firmware download option command 44
- Firmware numbers page command 43
- flawed sector reallocation 6
- FLOGI
 - received on Port A 40
 - received on Port B 40
- Force unit access command 44
- form factor 6
- format 33
- Format command execution time 9
- Format page (03h) command 43
- Format unit command 43
- front panel 29
- FS 38, 39, 41
- function
 - complete, code 00 37
 - not supported, code 05 37
 - reject, code 04 37

G

Good status 49
 gradient 25, 26
 ground shift noise 53
 grounding 36

H

hard assigned arbitrated loop physical address
 (AL_PA) 33
 HDA 25, 35, 36
 temperature 25
 head and disc assembly (HDA) 5
 head and disc assembly. *See* HDA
 heads
 read/write data 9
 heat removal 35
 heat source 35
 host equipment 36
 hot plugging the drive 15
 humidity 26
 humidity limits 24

I

IC 38
 ID and configuration options 6
 Implemented operating def. page command 43
 Information exceptions control page (1Ch) command
 43
 Initiator control 38
 Inquiry command 43
 inquiry data 46
 installation 33
 guide 4
 interface 33
 commands supported 43
 description 50
 error rate 13
 errors 13
 illustrated 50
 physical 50
 requirements 37
 interleave 6
 minimum 10
 intermediate/condition met/good status 49
 intermediate/good status 49
 Intermix 38, 41
 internal data rate 9
 internal defects/errors 31
 internal drive characteristics 9

J

J1 connector 33
 J6 connector 33, 34
 Jumper settings page command 43
 jumpers 33

L

latency
 average rotational 9, 10
 LBdata 45
 LED driver signals 57
 Link Service Reject (LS_RJT) 37
 link services supported 37
 Lock-unlock-cache command 44
 Log select command 45
 Log sense command 45
 logic power 53
 logical block address 11
 logical block reallocation scheme 6
 logical block size 6, 10
 logical segments 11
 Logout (LOGO) 37
 loop 50, 54
 disruption 15
 initialization 33
 loop position
 FC-AL options 42
 loop position report
 FC-AL options 42
 LS_RJT 38, 41
 LSI circuitry 7

M

maintenance 13
 maximum delayed motor start 21
 maximum start current 21
 mean time between failure (MTBF) 14
 media description 6
 minimum sector interleave 10
 miscellaneous feature support
 Adaptive caching 49
 Asynchronous event notification 49
 Automatic contingent allegiance 49
 Deferred error handling 49
 FC-AL selective reset 49
 Parameter rounding 49
 Queue tagging 49
 Reporting actual retry count 49
 Segmented caching 49
 SMP = 1 in Mode Select command 49
 Synchronized (locked) spindle operation 49
 Zero latency read 49
 miscellaneous status support
 ACA active 49
 ACA active, faulted initiator 49
 Busy 49
 Check condition 49
 Condition met/good 49
 Good 49
 Intermediate/condition met/good 49
 Intermediate/good 49
 Reservation conflict 49

- Task set full 49
- miscorrected media data 13
- Mode select
 - (10) command 45
 - command 43
- Mode sense
 - (10) command 45
 - command 43
 - data, table 46, 48
- monitoring state 15
- motor start
 - controls 54
 - option 10
- mounting 35
 - holes 35
 - orientations 34
- mounting configuration 29
- mounting configuration dimensions 29
- MTBF 13, 14, 24
 - defined 14

N

- N_Port Login (PLOGI) 37
 - payload 38
 - payload values 39
- NN 38, 41
- Node Name 41
- Node name 38
- noise
 - audible 3
- noise immunity 22
- non-operating 26, 28
 - temperature 25
- non-operating vibration 28

O

- office environment 28
- old port state
 - FC-AL options 42
- OPEN Full Duplex
 - FC-AL options 42
- OPEN half duplex
 - FC-AL options 42
- Open sequences per exchange 38
- operating 26, 28
- option configurations 33
- option selection 52
- options 7, 42
- orientation 26
- OS 38
- out-of-plane distortion 35
- overhead time
 - for head switch 10
 - for one track cylinder switch 10

P

- P_LOGI
 - received on Port A 39
 - received on Port B 39
- package size 27
- packaged 27
- parameter rounding 49
- pass-through state 15
- PBC 50, 54
- PBdata 45
- PCB
 - temperature 25
- PCBA 36
- peak bits per inch 9
- peak operating current 21
- peak-to-peak measurements 22
- PECL input 58
- performance characteristics
 - detailed 9
 - general 10
- performance degradation 26
- performance highlights 6
- physical damage 28
- physical interface 50
 - description 50
- physical specifications 21
- PI 39, 40
- pin descriptions 52
- PN 38, 41
- port bypass circuit 15, 50, 54
- port bypass LED connection 33
- Port DIScovery 38
- Port Discovery (PDISC) 37
- port identifier field 39, 40
- port login 38
 - accept 39
- Port Name 41
- Port name (initiator's) 38
- power 53
 - dissipation 24
 - requirements, AC 21
 - requirements, DC 21
 - sequencing 22
- Power control page (1Ah) command 43
- power distribution 3
- Prefetch command 44
- prefetch/multi-segmented cache control 10
- preventive maintenance 13
- printed circuit board (PCB)
 - cooling 34
- private loop
 - FC-AL options 42
- Proc Assc 38
- Process Accept (ACC) 39
- Process Login (PRLI) 37, 39
- Process Login Accept (ACC) payload 39
- process login payload data 39

Process Logout (PRLO) 37

public loop

FC-AL options 42

pull down resistor 54

Q

queue tagging 49

R

radio interference regulations 3

Random relative offset 38, 41

RCD bit 11

Read buffer command 44

Read capacity command 44

Read combined header and data mode (0) 44

Read command 43

Read data mode (2) 44

Read defect data command 44

Read descriptor mode (3) 44

read error rates 13

Read extended command 44

Read Link Status (RLS) 37

Read long command 44

read/write data heads 9

Reassign blocks command 43

Receive buffer field size 38, 41

receive buffer field size 39

Receive diagnostic results command 43

receive eye

diagram 58

receivers 53

recommended mounting 27

recovered media data 13

reference

documents 4

Regenerate command 45

Register FC-4 Types (RFT_ID) 37

Relative address command 44

relative humidity 26

Release command 43

Released (10) command 45

reliability 7

and service 14

specifications 13

repair and return information 19

reporting actual retry count 49

Request sense command 43

reservation conflict status 49

Reserve command 43

Reserved (10) command 45

resonance 26

return information 19

Rezero unit command 43

Rigid disc drive geometry page

command 43

rotation speed 9

running disparity 15

S

safety 3

SCA part numbers 51

SCSI interface

commands supported 43

Search data

equal command 44

high command 44

low command 44

Seek command 43

seek error

defined 13

rate 13

Seek extended command 44

seek performance characteristics 9

seek time

average typical 9

full stroke typical 9

single track typical 9

segmented caching 49

SEL ID 33

lines 54

standard feature 6

Self-Monitoring Analysis and Reporting Technology

7, 15

Send diagnostics page command 43

Sequential delivery 38, 41

service

life 15

philosophy 15

tools 15

Service Options 41

Service options 38

Set limits command 44

shielding 3

shipping 19

shipping container 25

shock 26

and vibration 26

shock mount 36

signal

characteristics 57

LED driver 57

single-unit shipping pack kit 7

SMART 7, 15

SMP = 1 in Mode Select command 49

SO 38, 41

spindle brake 6

Stacked connection req. 38, 41

standards 3

Start unit/stop unit command 43

start/stop time 10

support services 59

Supported diagnostics pages command 43, 44

surface stiffness

allowable for non-flat surface 35

switches 33

Synchronize cache command 44
 synchronized spindle
 operation 49
 system chassis 36

T

target reset function 37
 task management functions 37
 Abort task set 37
 Clear ACA 37
 Clear task set 37
 Target reset 37
 terminate task 37
 task management response codes 37
 Function complete 00 37
 Function not supported 05 37
 Function reject 04 37
 task set full status 49
 technical support services 59
 temperature 24, 35
 ambient 24
 case 24
 gradient 24
 limits 24
 non-operating 25
 PCB and HDA 25
 regulation 3
 See also cooling
 terminate task function 37
 terminators 33
 Test unit ready command 43
 Third-party Process Logout (TRPLO) 37
 tracks per inch 9
 tracks per surface 9
 Translate page command 43, 44
 transmit eye diagram 58
 transmitters 53
 transporting the drive 19
 TTL input characteristics 57

U

UI 39, 40
 unique identifier 39, 40
 Unit attention page (00h) command 43
 Unit serial number page command 43
 unrecoverable
 error 13
 write error, defined 13
 unrecovered media data 13

V

Valid version level 38, 41
 Verify command 44
 Verify error recovery page (07h) command 43
 vibration 26, 28
 Vital product data page command 43

W

warranty 19
 word sync 15
 Write and verify command 44
 Write buffer command 44
 Write combined header and data mode (0) 44
 Write command 43
 Write data mode (2) 44
 write errors 13
 Write extended command 44
 Write long command 44
 Write same command 45

X

XD read 45
 XD write 45
 XD write extended command 45
 XID reassign 38
 XP write 45

Z

zero latency read 49
 zone bit recording (ZBR) 6



Seagate Technology LLC
920 Disc Drive, Scotts Valley, California 95066-4544, USA
Publication Number: 83329486, Rev. C, Printed in USA